



October 15, 2014

Subject: USG Shaftwall and Area Separation Wall Systems

To Our Customers:

Effective immediately, we are pleased to announce that EB Metal Inc. (Edouard Beuchesne 1985 Inc.) will become an additional authorized manufacturer of steel components for USG's Shaft Wall and Area Separation Wall Systems as found in USG's SA926/SA925 brochures.

EB Metal operates in Canada and the Northeastern United States (CT, NH, NY, NJ, PA, RI, VT, MA and ME).

For more information, visit www.ebmetal.us.

Sincerely,

A handwritten signature in black ink, appearing to read "Robert Kay", written in a cursive style.

Robert Kay
Product Manager - Drywall Systems

CERTIFICATE OF COMPLIANCE

Certificate Number 20150121-R38201
Report Reference R38201-20150121
Issue Date 2015-JANUARY-21

Issued to: E.B. Metal Inc
3211 Rue de l'Industrie
St-Mathieu-de-Beloil
QC J3G 4S5 CANADA

This is to certify that
representative samples of

FRAMING MEMBERS

The products covered in this section are channel-shaped
steel studs for use in wall assemblies.

Have been investigated by UL in accordance with the
Standard(s) indicated on this Certificate.

Standard(s) for Safety:

CAN/ULC S101 - FIRE ENDURANCE TESTS OF
BUILDING CONSTRUCTION AND MATERIALS
UL 263 - STANDARD FOR FIRE TESTS OF BUILDING
CONSTRUCTION AND MATERIALS

Additional Information:

See the UL Online Certifications Directory at
www.ul.com/database for additional information

Only those products bearing the UL Certification Mark should be considered as being covered by UL's
Certification and Follow-Up Service.

Look for the UL Certification Mark on the product.

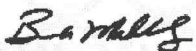

Bruce Mahrenholz, Assistant Chief Engineer, Global Inspection and Field Services

UL LLC

Any information and documentation involving UL Mark services are provided on behalf of UL LLC (UL) or any authorized licensee of UL. For questions, please
contact a local UL Customer Service Representative at www.ul.com/contactus



USG
Interior
Panel &
Finishing
Solutions

USG SHAFT WALL SYSTEMS

LIFE SAFETY ASSURANCE
FOR MODERN BUILDING DESIGNS

usg.com

USG 
IT'S YOUR WORLD. BUILD IT.®



HIGH-PERFORMANCE SHAFT WALLS

Walls that enclose elevator shafts, stairwells and other vertical shafts are the lifeline of a building. Should a fire occur, firefighters control the use of elevators, leaving stairwells as the only means for occupant egress or rescue within the building. Since these walls are an important part of the building, they must have the strength to withstand lateral loads and provide needed fire protection.

USER'S GUIDE

This brochure explains:

- What a shaft wall system comprises
- The different applications where shaft wall systems can be used
- How to select and specify the appropriate components of a shaft wall system

Pages

UNDERSTAND YOUR SYSTEM	
Overview	4
Applications	
Components	
Performance Testing	
SELECT YOUR SYSTEM	
Performance Selector	14
Limiting Heights	
Solid Shaft Wall	
Limiting Spans	
DESIGN YOUR SYSTEM	
Design Details	23
Good Design Practices	
SPECIFY YOUR SYSTEM	
Application Guide Specifications	36

OVERVIEW

USG Shaft Wall Systems are non-load-bearing gypsum wall partition assemblies constructed from outside the shaft at each floor. Shafts are enclosed early in construction, and the walls are finished later, along with interior partitions. Installation is quick and easy, using components and application procedures familiar to drywall contractors. This system installs faster than other multilayer gypsum panel systems because it is installed from one side, leaving the shaft free of scaffolding. The assemblies are constructed of gypsum liner panels friction-fitted into C-H studs in a progressive manner, with gypsum panels, gypsum fiber panels or cement board applied to the face.

All details, specifications and data contained in this literature are intended as a general guide. These products must not be used in a design or construction of any given structure without complete and detailed evaluation by a qualified structural engineer or architect to verify suitability of a particular product for use in the structure.

TYPICAL SHAFT WALL ASSEMBLY

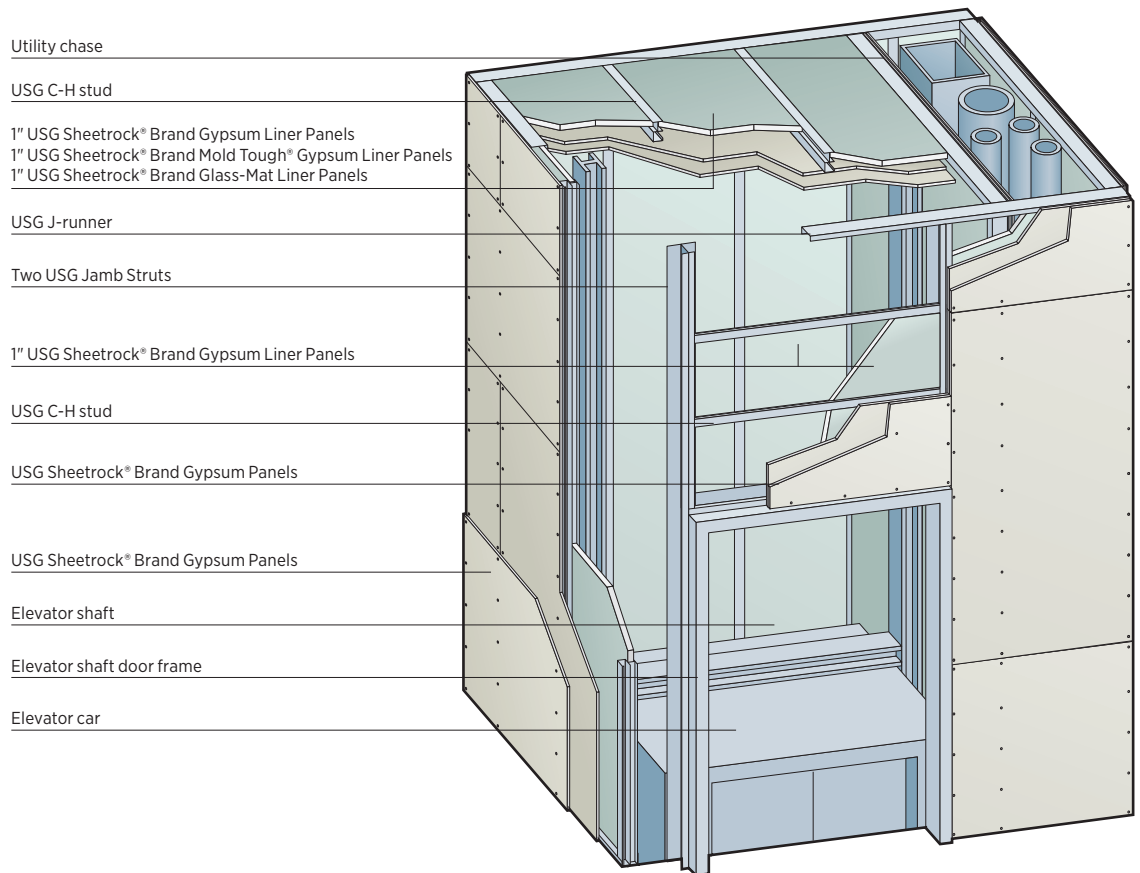

APPLICATIONS

Use USG Shaft Wall Systems to construct elevator shafts, mechanical shafts, stairwells, air return shafts and horizontal membranes. These shafts are vital for vertical communication, power, water, fresh air, exhaust and a means of egress.

WALLS

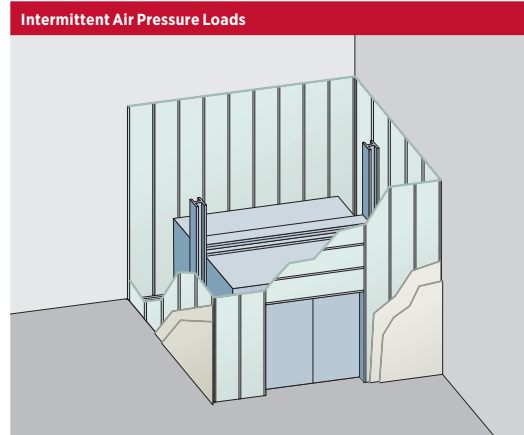

Elevator shafts
Ideal for elevator shafts since the walls can be constructed from one side, leaving the shaft free of scaffolding. This allows elevator equipment to be installed simultaneously.

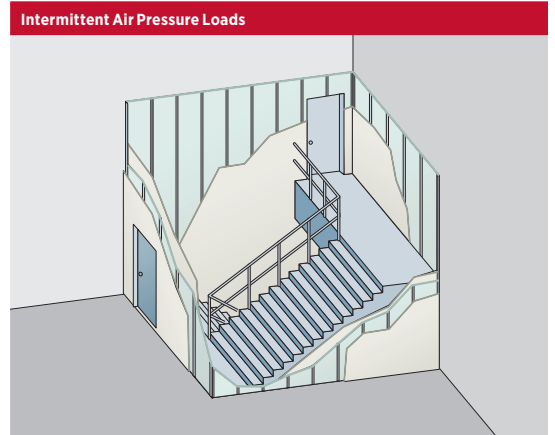

Stair shafts
Accommodates stair shafts by allowing both sides of the wall to be finished when required. For added abuse resistance in stairwells, face layer panels can be substituted with USG Sheetrock® Brand Mold Tough® AR Firecode® X, USG Sheetrock® Brand Mold Tough® VHI Firecode® X or USG Fiberock® Abuse-Resistant Interior Panels.

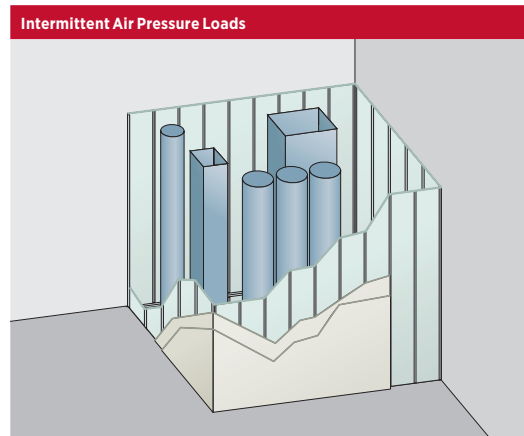

Mechanical shafts
Vertical HVAC piping and ductwork can easily be contained within the system, as well as allowing for wall penetrations when required.

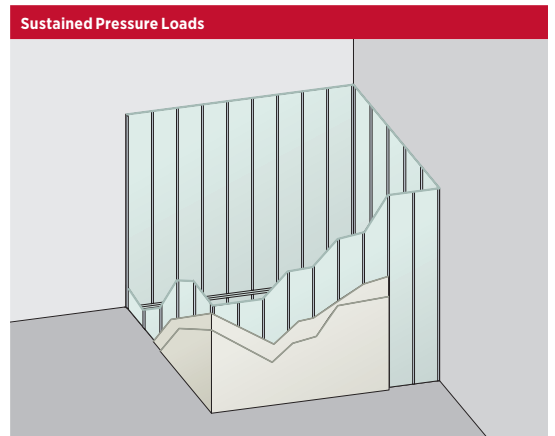

Air shafts (unlined)
The system can also be used for vertical air shafts within the building. Shafts can be unlined when specific conditions are met. Unlined shaft walls can accommodate sustained air pressure up to 10 psf. See page 20 for more information.

APPLICATIONS

Use USG Shaft Wall Systems to construct elevator shafts, mechanical shafts, stairwells, air return shafts and horizontal membranes. These shafts are vital for vertical communication, power, water, fresh air, exhaust and a means of egress.

WALLS

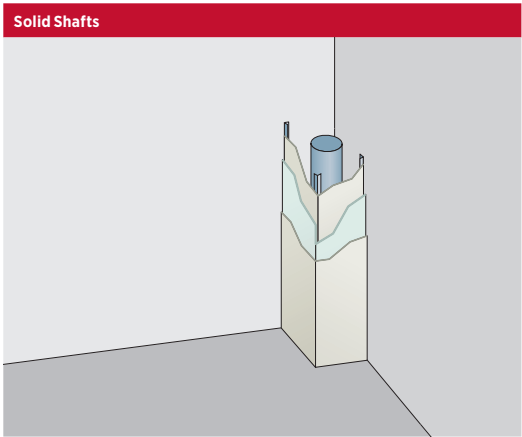

Solid shafts are normally used to construct mechanical or duct enclosures, or in areas where a small section of shaft wall is needed for a single vertical pipe penetration. See page 21 for more information.

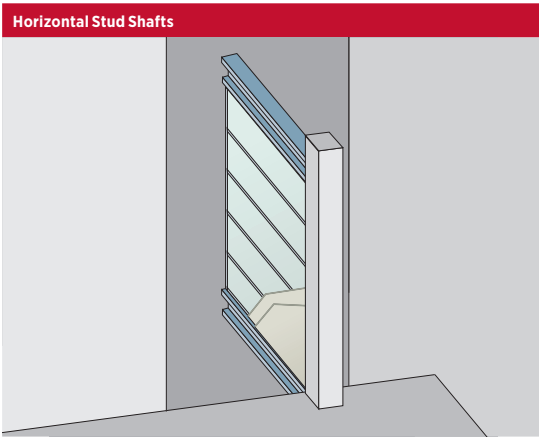

For certain applications, equipment limitations sometimes make it difficult to install shaft liner panels and studs vertically. This is true for walls separating shafts when there is only a structural beam provided for supporting the wall.

CEILINGING

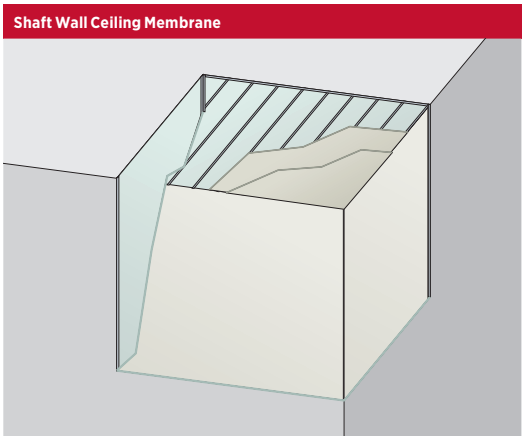

The two-hour horizontal membrane (also used in two-hour duct enclosures), and the membranes used as the ceiling of one- and two-hour egress corridors, are shown on page 23. When the span of the two-hour horizontal membrane is greater than 5'-4", use Underwriters Laboratories Inc. (UL) Design K504 and K506, per details on page 24.

COMPONENTS

USG Shaft Wall Systems have been comprehensively tested for fire resistance ratings only when all of the system components are used together. Substitutions of any of the components are not recommended and are not supported by USG. Refer to the appropriate product Safety Data Sheet for complete health and safety information.

GYPSUM LINER PANELS

USG Sheetrock® Brand Gypsum Liner Panels (UL Type SLX)

- High-performance panel has a noncombustible core encased in a water-resistant, 100% recycled green face and back paper
- UL/ULC Classification as to fire resistance, surface burning characteristics and noncombustibility
- Panel is 1" thick and 24" wide with beveled edges
- Refer to product submittal sheet WB2278 for more information

USG Sheetrock® Brand Mold Tough® Gypsum Liner Panels (UL Type SLX)

- High-performance panel has a noncombustible and moisture- and mold-resistant gypsum core enclosed in a moisture- and mold-resistant, 100% recycled blue face and back paper
- UL/ULC Classification as to fire resistance, surface burning characteristics and noncombustibility
- Panel is 1" thick and 24" wide with beveled edges
- Refer to product submittal sheet WB2389 for more information

USG Sheetrock® Brand Glass-Mat Liner Panels (UL Type SLX)

- High-performance panel has a noncombustible and moisture- and mold-resistant gypsum core enclosed in a moisture- and mold-resistant glass mat on both sides
 - Can be left exposed for up to 12 months
 - UL/ULC Classification as to fire resistance, surface burning characteristics and noncombustibility
 - Panel is 1" thick and 24" wide with beveled edges
 - Refer to product submittal sheet WB2483 for more information
-

GYPSUM PANELS AND CEMENT BOARD

USG Sheetrock® Brand Firecode® X Panels (UL Type SCX)

- All of the advantages of regular panel with additional resistance to fire
- UL/ULC Classification as to fire resistance, surface burning characteristics and noncombustibility
- Available in 5/8" thickness, 4' width
- Refer to product submittal sheet WB1473 for more information

USG Sheetrock® Brand UltraLight Panels Firecode® X (UL Type ULX and ULIX)

- All of the advantages of USG Sheetrock® Brand Firecode® X Gypsum Panels
- Lighter weight makes it easier to transport, handle and install
- UL/ULC Classification as to fire resistance, surface burning characteristics and noncombustibility
- Available in 5/8" thickness, 4' width
- Refer to product submittal sheet WB2598 for more information

USG Sheetrock® Brand Firecode® C Panels (UL Type C)

- Provide improved fire resistance over standard USG Sheetrock® Brand Firecode® X Panels because of additives that enhance integrity of the core under fire exposure
- UL/ULC Classification as to fire resistance, surface burning characteristics and noncombustibility
- Available in 5/8" and 1/2" thicknesses, 4' width
- Refer to product submittal sheet WB1473 for more information

COMPONENTS

USG Sheetrock® Brand Mold Tough® Firecode® X Panels (UL Type SCX)

- Panel has a noncombustible, moisture- and mold-resistant gypsum core encased in a moisture- and mold-resistant, 100% recycled green face and brown back paper
- Tapered long edges for easy finishing
- UL/ULC Classification as to fire resistance, surface burning characteristics and noncombustibility
- Available in 5/8" thickness, 4' width
- Refer to product submittal sheet WB2390 for more information

USG Sheetrock® Brand Mold Tough® AR Firecode® X Panels (UL Type AR)

- Panel has a noncombustible, moisture- and mold-resistant gypsum core encased in a moisture- and mold-resistant, 100% recycled green face and brown back paper
- Tapered long edges for easy finishing
- UL/ULC Classification as to fire resistance, surface burning characteristics and noncombustibility
- Available in 5/8" thickness, 4' width
- Manufactured for greater abuse resistance than standard 5/8" gypsum panels
- Meet ASTM C1629 Level 2 for soft-body impact and surface abrasion and Level 1 for indentation resistance
- Refer to product submittal sheet WB2391 for more information

USG Sheetrock® Brand Mold Tough® VHI Firecode® X Panels (UL Type AR)

- Panel has a noncombustible, moisture- and mold-resistant gypsum core encased in a moisture- and mold-resistant, 100% recycled green face and brown back paper
- Tapered long edges for easy finishing
- UL/ULC Classification as to fire resistance, surface burning characteristics and noncombustibility
- Available in 5/8" thickness, 4' width
- Core is reinforced with a high-strength mesh for heavy-duty impact resistance
- Meet ASTM C1629 Level 3 for soft- and hard-body impact resistance
- Refer to product submittal sheet WB2529 for more information

USG Sheetrock® Brand Glass-Mat Panels Mold Tough® Firecode® X (UL Type SGX)

- Panel has a noncombustible, moisture- and mold-resistant gypsum core encased in a moisture- and mold-resistant fiberglass mat
- Tapered long edges for easy finishing
- UL/ULC Classification as to fire resistance, surface burning characteristics and noncombustibility
- Available in 5/8" thickness, 4' width
- Suitable for use in pre-dry-in (fast track) and similar applications of wallboard before the building envelope is fully enclosed
- Can be exposed to weather up to 12 months
- Refer to product submittal sheet WB2560 for more information

USG Sheetrock® Brand Glass-Mat Panels Mold Tough® AR (UL Type AR)

- Panel has a noncombustible, moisture- and mold-resistant gypsum core encased in a moisture- and mold-resistant fiberglass mat
- Provide greater abuse resistance compared to standard drywall
- Meet ASTM C1629 Level 3 for abrasion and soft-body resistance
- Suitable for use in pre-dry-in (fast track) and similar applications of wallboard before the building envelope is fully enclosed
- UL/ULC Classification as to fire resistance, surface burning characteristics and noncombustibility
- Available in 5/8" thickness, 4' width
- Can be exposed to weather up to 12 months
- Refer to product submittal sheet WB2750 for more information

COMPONENTS

USG Sheetrock® Brand Glass-Mat Panels Mold Tough® VHI (UL Type AR)

- Panel has a noncombustible, moisture- and mold-resistant gypsum core encased in a moisture- and mold-resistant fiberglass mat
- Provide superior impact resistance and are an upgrade to abuse-resistant panels
- Meet ASTM C1629 Level 3 for hard- and soft-body impact resistance
- Suitable for use in pre-dry-in (fast track) and similar applications of wallboard before the building envelope is fully enclosed
- UL/ULC Classification as to fire resistance, surface burning characteristics and noncombustibility
- Available in 5/8" thickness, 4' width
- Can be exposed to weather up to 12 months
- Refer to product submittal sheet WB2749 for more information

USG Sheetrock® Brand Ultracode® Core Panels (UL Type ULTRACODE)

- 3/4" thick panel can achieve a two-hour fire rating with single-layer construction when used with mineral wool insulation in steel framed walls
- Available in 4' width
- Refer to product submittal sheet WB2167 for more information

USG Sheetrock® Brand Mold Tough® Ultracode® Core Panels (UL Type ULTRACODE)

- 3/4" thick panel can achieve a two-hour fire rating with single-layer construction when used with mineral wool insulation in steel framed walls
- Panel has a noncombustible, moisture- and mold-resistant gypsum core encased in moisture- and mold-resistant green face and brown back paper
- UL/ULC Classification as to fire resistance, surface burning characteristics and noncombustibility
- Refer to product submittal sheet WB2388 for more information

USG Durock® Brand Cement Board (UL Type DCB)

- Water-durable, mold-resistant substrate for high-moisture areas
- Refer to product submittal sheet CB399 for more information

USG Fiberock® Abuse-Resistant Interior Panels (UL Type FRX-G)

- Resist denting, breaking and puncturing, even in high-traffic areas
- Excellent fire resistance
- Made from 95% recycled materials
- Refer to product submittal sheet F102 for more information

USG Fiberock® Aqua-Tough™ Interior Panels (UL Type FRX-G)

- Used only for wall designs
- Increased resistance to abrasion, indentation and penetration
- Made from 95% recycled materials
- Refer to product submittal sheet F134 for more information

USG Imperial® Gypsum Base, Firecode® X (UL Type IP-X1) and Firecode® C (UL Type IP-X2)

- Panels offered in a range of sizes, rigid base for fire-rated gypsum veneer plaster systems
- Designed for direct or resilient attachment to wood or steel framing core composition
- Multilayered face paper to control water absorption and resist sag
- Refer to product submittal sheet P790 for more information

COMPONENTS

STEEL FRAMING

USG Steel J-Runner (JR)

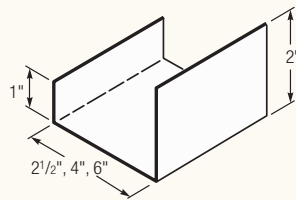

USG Steel C-H Stud (CH)

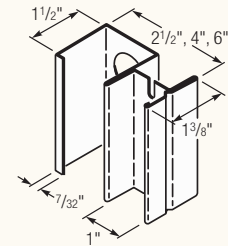

USG Steel Jamb-Strut (JS)

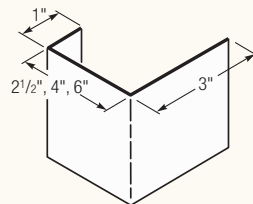

USG Steel E-Stud (ES)

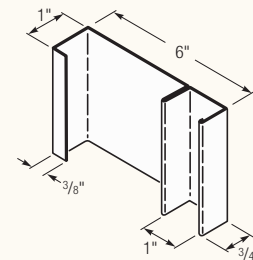

Thickness-Steel Framing^a Components

Style	Design Thickness ^b		Minimum Thickness		
	in.	mils	in.	mils	ga.
CH, ES	0.0188	18	0.0179	18	25
JR	0.0239	22	0.0227	23	24
CH, ES, JR, JS	0.0359	33	0.0341	34	20

Structural Properties-Steel Framing Components

Component and Size	Product Identification	Average Weight (lb./lin. ft.)	Area (sq. in.)	I _x (in. ⁴)	S _x ^c (cu. in.)	Allowance Design Stress (ksi)
2-1/2" C-H Stud	212CH-18	0.5186	0.1524	0.129	0.093	19.8
	212CH-34	0.998	0.2910	0.239	0.1741	24.0
4" C-H Stud	400CH-18	0.6118	0.1798	0.383	0.162	19.8
	400CH-34	1.243	0.3433	0.730	0.318	24.0
6" C-H Stud	600CH-34	1.366	0.4227	1.998	0.569	24.0
Double 6" E-Stud	600ES-18	1.546	0.3982	2.004	0.628	20.00
	600ES-34	2.372	0.6364	3.400	1.094	20.00
2-1/2" J-Runner	212JR-23	0.448	0.1346	0.117	0.085	3.00
	212JR-34	0.670	0.2039	0.192	0.130	4.96
4" J-Runner	400JR-23	0.573	0.1705	0.351	0.163	3.00
	400JR-34	0.857	0.2577	0.574	0.251	4.96
6" J-Runner	600JR-23	0.740	0.2183	0.937	0.295	3.00
	600JR-34	1.107	0.3295	1.523	0.457	4.96
2-1/2" Jamb Strut	212JS-34	0.818	0.2398	0.226	0.143	3.00
4" Jamb Strut	400JS-34	1.006	0.2936	0.647	0.270	3.00
6" Jamb Strut	600JS-34	1.256	0.3654	1.673	0.485	3.00

Note

(a) Studs and runners comply with ASTM C645.

(b) Properties of steel framing members have been calculated in conformance with ANSI Specification for the Design of Cold-Formed Steel Structural Members, 1996 edition.

(c) Full section modulus to be used with corresponding design stress.

COMPONENTS

INTERIOR FINISHING PRODUCTS

USG Sheetrock® Brand Acoustical Sealant

- Superior performance as a fire caulk in UL-Classified joint systems
- Minimizes whistling and dirt accumulation due to air movement when applied to partition perimeter and penetrations
- Refer to product submittal sheet J678 for more information

USG Sheetrock® Brand First Coat™ Primer

- A flat latex paint formulated to provide a superior first (prime) coat over interior gypsum board and concrete surfaces
- Equalizes porosity and surface texture differences to provide greater uniformity of finish coat
- Refer to product submittal sheet J1095 for more information

USG Sheetrock® Brand All Purpose Joint Compound

- Versatile performer: tape, finish, texture, laminate or skim coat
- Combines single-package, ready-mixed convenience with good taping and topping performance
- Refer to product submittal sheet J60A for more information

USG Sheetrock® Brand Plus 3® Lightweight All Purpose Joint Compound

- Weighs up to 30% less than conventional compounds and sands with the ease of a topping compound
- With very low shrinkage, it requires only two coats over metal, such as corner beads and fasteners
- Refer to product submittal sheet J498A for more information

USG Sheetrock® Brand Tuff-Hide™ Primer-Surfacer

- A high solids, vinyl, acrylic latex-based coating for interior spray application over new drywall
- Single spray application provides the same results achieved using a typical two-step process of skim coating surfaces with joint compound followed by a coat of primer
- Saves time and money
- Refer to product submittal sheet J1691 for more information

USG Sheetrock® Brand Paper-Faced Metal Corner Bead and Trim

- Cost-effective, problem-free, beautiful corners
- Superior solution to edge cracking and chipping
- Refer to product submittal sheet J1356 for more information

PERFORMANCE TESTING

USG Shaft Wall Systems provide superior safety and performance for an important building component.

PERFORMANCE TESTS

USG Shaft Wall Systems result from a program of extensive testing and continuous improvements to help you achieve the superior performance that your project demands. Systems provide up to four-hour fire resistance and sound ratings up to 52 Sound Transmission Class (STC), and resist both sustained and intermittent lateral loads and fatigue under cyclic lateral loading.

TESTING METHODS

All USG products and systems undergo exhaustive testing to ensure that they meet exacting standards. USG products are classified as to fire resistance and fire-hazard properties. As part of this protocol, UL periodically audits production of these materials to ensure compliance with necessary properties. UL is an independent, not-for-profit organization that has tested products for public safety for over a century.

Products are manufactured and tested in accordance with recognized standards. ASTM International is one of the largest voluntary standards development organizations in the world, and is a trusted source for technical standards for materials, products, systems and services.

These systems have been designed and tested using accepted engineering practices with deflection limits of L/120, L/240 and L/360. Additionally, limiting height tables listed herein account for flexural and shear stresses. A wide range of product and system combinations is available to meet performance requirements: intermittent and sustained air pressure loading of 5, 7-1/2, 10 and 15 psf.

TESTING RESULTS

Fire Protection: In the event of a fire, mechanical shafts and stairs are vital channels for communication, power, water, air, exhaust and egress—making the shafts the lifelines of the building. Since it is critically important that these walls protect occupants and necessary services from fire, USG Shaft Wall Systems have been tested for fire endurance.

The primary attribute of USG Shaft Wall Systems and their components is fire resistance. Testing supporting this attribute ensures that this critical performance component will not be compromised when properly installed.

This fire testing results in the following:

- UL Classification of all gypsum panel components
- UL fire resistance Classifications for one- to four-hours
- UL system testing with all major elevator door manufacturers
- UL listing for fire damper installation
- Fire test data for electrical panels, call-button boxes and other interfaces
- UL listing of shaft wall head of wall

See the Good Design Practices section for more information on fire resistance.

Sound Control: Sound control test data demonstrate the effectiveness of USG Shaft Wall Systems in attenuating sound. When properly designed and installed, USG Shaft Wall Systems will increase comfort levels by reducing unwanted noise from adjacent spaces.

The standard assembly offers 39 STC rating; 47 STC is achieved by adding 1" sound insulation within the partition cavity, and 52 STC with single-layer 3/4" USG Sheetrock® Brand Ultracode® Core Panels and 3" sound insulation.

PERFORMANCE TESTING

TESTING RESULTS

Impact Resistant for Durability: Performance utilizing abuse-resistant and impact-resistant gypsum panels like USG Sheetrock® Brand Mold Tough® AR or VHI Firecode® X Panels. USG Shaft Wall Systems meet requirements of IBC Sections 403.2.3.1 and 403.2.3.2.

Moisture/Mold: The best way to minimize damage from moisture and mold is to minimize or eliminate exposure to water before, during and after construction. In all cases where moisture intrusion occurs, eliminate all sources of moisture immediately.

USG Sheetrock® Brand Gypsum Liner Panels, USG Sheetrock® Brand Mold Tough® Gypsum Liner Panels and USG Sheetrock® Brand Glass-Mat Liner Panels have water-resistant facings. In addition, USG Sheetrock® Brand Mold Tough® and USG Sheetrock® Brand Glass-Mat Liner Panels have moisture- and mold-resistant facings and a water-resistant core.

When used in conjunction with good construction practices, these products will minimize, but not eliminate, the risk of moisture and mold damage. For more information on moisture control and mold, see *Moisture, Mold and Construction Practices* (WB2317), and *Moisture-Resistant Assemblies* (SA934). The following websites are other resources:

New York City Department of Health

nyc.gov/html/doh/html/environmental/mold.shtml
Search for mold resources.

United States Environmental Protection Agency

epa.gov
Search for mold resources.

Responsible Solutions to Mold Coalition

responsiblemoldsolutions.org
Search for mold resources.

PERFORMANCE SELECTOR

ALTERNATIVE MATERIALS AND SPECIAL REQUIREMENTS

The following notes offer alternative methods of construction:

1. Where insulation by composition is shown in assembly drawings, the specific type of product is required in the assembly to achieve the stated fire-resistance rating. Otherwise, mineral wool or glass fiber insulation may be incorporated into any assembly without compromising the fire-resistant rating.
2. Stud depths are minimum required for fire-resistant rating.
3. Where RC-1 resilient channel is indicated, RC-1 or equivalent may be used. RC-2 is not an equivalent substitution.
4. Use L/360 deflection criteria for limiting height/stud selection and 20 ga. minimum framing when applying USG Durock® Brand Cement Board. Refer to *USG Durock® Brand Cement Board* submittal (CB399), for more information on application and related products.
5. 5/8" USG Imperial® Gypsum Base, 5/8" USG Sheetrock® Brand Mold Tough® Firecode® X Panels or 5/8" USG Fiberock® Aqua-Tough™ Interior Panels may be substituted for 5/8" USG Sheetrock® Brand Firecode® X Panels.
6. 1/2" USG Sheetrock® Brand Mold Tough® Firecode® C or 1/2" USG Imperial® Gypsum Base, Firecode® C may be substituted for 1/2" USG Sheetrock® Brand Firecode® C Panels.
7. Use 20 ga. minimum framing with USG Sheetrock® Brand Mold Tough® AR and VHI Firecode®, USG Sheetrock® Brand Glass-Mat Panels Mold Tough® AR and VHI, USG Durock® Brand Cement Board or USG Fiberock® Panels.
8. 1" USG Sheetrock® Brand Mold Tough® Gypsum Liner Panels, or USG Sheetrock® Brand Glass-Mat Liner Panels may be substituted for 1" USG Sheetrock® Brand Gypsum Liner Panels in all systems without compromising the fire rating.
9. For more information about performance-rated shaft wall systems and for complete list of USG's fire-rated designs, visit USG Design Studio at usgdesignstudio.com.
10. For detailed information regarding UL Classified designs shown in the Performance Selector, please refer to the UL Fire Resistance Directory at ul.com.

PERFORMANCE SELECTOR

All details, specifications and data contained in this literature are intended as a general guide. These products must not be used in a design or construction of any given structure without complete and detailed evaluation by a qualified structural engineer or architect to verify suitability of a particular product for use in the structure.



ONE-HOUR FIRE-RATED CONSTRUCTION

TWO-HOUR FIRE-RATED CONSTRUCTION

Construction Detail	Non-loadbearing Description	Test Number	Acoustical Performance		Reference	
			STC	Test Number	ARL	Index
wt. 8 	<ul style="list-style-type: none"> • 5/8" USG Sheetrock® Brand Firecode® X Panels, joints finished • 2-1/2" USG C-H studs 25 gauge 24" o.c. • 1" USG Sheetrock® Brand Gypsum Liner Panels 	UL Design U415, System A or U469	39	USG-040901 Based on 4" C-H studs 25 gauge	SA926	1
wt. 9 	<ul style="list-style-type: none"> • 1/2" USG Sheetrock® Brand Firecode® C Panels, face layer joints finished • 2-1/2" USG C-H studs 25 gauge 24" o.c. • 1" USG Sheetrock® Brand Gypsum Liner Panels 	UL Design U415, System B or U438	38	USG-040917	SA926	2
			43	USG-040917 Based on 4" C-H studs 25 gauge		
			48	RAL-OT-04-022 Based on 1" sound batts in cavity		
wt. 8 	<ul style="list-style-type: none"> • 3/4" USG Sheetrock® Brand Ultracode® Core Panels, joints finished • 4" USG C-H studs 25 gauge 24" o.c. • 3" Thermafiber® SAFB • 1" USG Sheetrock® Brand Gypsum Liner Panels 	UL Design U415, System C	51	RAL-OT-04-020 Based on 4" C-H studs with 3" Thermafiber® SAFB insulation	SA926	3
			wt. 10 	<ul style="list-style-type: none"> • 1/2" USG Durock® Brand Cement Board • 5/8" USG Sheetrock® Brand Firecode® X Panels • 2-1/2" USG C-H studs 20 gauge 24" o.c. • 1-1/2" Thermafiber® SAFB • 1" USG Sheetrock® Brand Gypsum Liner Panels • USG Durock® Brand Cement Board, screw attached and laminated to gypsum panel with four vertical strip ceramic tile mastic centered between studs 	UL Design U415, System D	
wt. 9 	<ul style="list-style-type: none"> • 1/2" USG Sheetrock® Brand Firecode® C Panels • 2-1/2" USG C-H studs 25 gauge 24" o.c. • 1" USG Sheetrock® Brand Gypsum Liner Panels • Joints finished both sides 	UL Design U415, System E or U467	44	USG-040911 Based on 4" C-H studs 25 gauge	SA926	5
wt. 10 	<ul style="list-style-type: none"> • 1/2" USG Sheetrock® Brand Firecode® C Panels applied vertically, face layer joints finished • RC-1 resilient channel or equivalent 24" o.c. • 2-1/2" USG C-H studs 25 gauge 24" o.c. • 1" USG Sheetrock® Brand Gypsum Liner Panels 	UL Design U415, System F	53	USG-040909 Based on 4" C-H studs 25 gauge with 3" mineral fiber insulation	SA926	6
			58	USG-040910 Based on 4" C-H studs 25 gauge with additional layer on liner panel side and 3" mineral fiber insulation		
wt. 8 	<ul style="list-style-type: none"> • 1" x 2" perimeter angles 25 gauge • 1" USG Sheetrock® Brand Gypsum Liner Panels, fastened to angles • 1/2" USG Sheetrock® Brand Firecode® C Panels, joints finished 	UL Design U529			SA926	7

PERFORMANCE SELECTOR



TWO-HOUR FIRE-RATED CONSTRUCTION

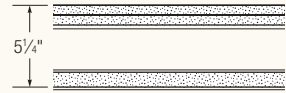

THREE-HOUR FIRE-RATED CONSTRUCTION

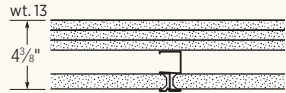

FOUR-HOUR FIRE-RATED CONSTRUCTION

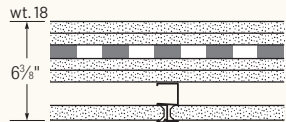

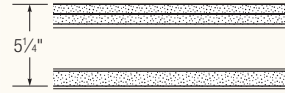
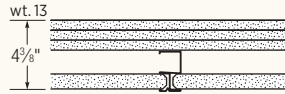
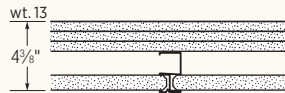
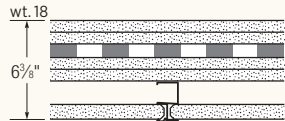
Construction Detail	Non-loadbearing		Acoustical Performance		Reference	
	Description	Test Number	STC	Test Number	ARL	Index
	<ul style="list-style-type: none"> 5/8" USG Sheetrock® Brand Firecode® X Panels, face layer joints finished 4" USG C-H studs 20 gauge 24" o.c. run horizontally and attached to vertical USG J-runners, 20 gauge 1" USG Sheetrock® Brand Gypsum Liner Panels 	UL Design U437		USG-040901 Based on 4" C-H studs 25 gauge	SA926	8
	<ul style="list-style-type: none"> 5/8" USG Sheetrock® Brand Firecode® C Panels, face layer joints finished 2-1/2" USG C-H studs 25 gauge 24" o.c. 1" USG Sheetrock® Brand Gypsum Liner Panels 	UL Design U415, System G			SA926	9
	<ul style="list-style-type: none"> 5/8" USG Sheetrock® Brand Firecode® C Panels, face layer joints finished 2-1/2" USG C-H studs 25 gauge 24" o.c. 1" USG Sheetrock® Brand Gypsum Liner Panels 5/8" USG Sheetrock® Brand Firecode® C Panels, joints finished 	UL Design U415, System H	49	USG-040902 Based on 4" C-H studs	SA926	10
	<ul style="list-style-type: none"> 3/4" USG Sheetrock® Brand Ultracode® Core Panels, on furring channel 24" o.c., over two layers, face layer joints finished 2-1/2" USG C-H studs 25 gauge 24" o.c. 1" USG Sheetrock® Brand Gypsum Liner Panels Base layer over furring channel applied vertically 	UL Design U415, System I			SA926	11

Note
Stud size and gauge shown are minimums. Possible panel substitutions.

PERFORMANCE SELECTOR

WALL SYSTEMS—LIMITING HEIGHTS

USG Shaft Wall Systems are engineered to withstand pressure loads and provide in-service impact resistance to ensure long-term performance and durability. Use this section to determine the size and gauge of framing for the system you select. You will need to know elevator pressures and other in-service demands.

STRUCTURAL PERFORMANCE

Flexing Resistance for In-Service Performance: Shaft walls are subjected to both positive and negative pressures as elevator cabs rise and descend. This piston effect of an elevator in its shaft causes continual flexing of the shaft wall. In tests, USG Shaft Wall Systems were subjected to over 1 million full oscillation cycles to model wall performance through the life of the building. These tests showed that a 25 ga. J-runner is inadequate at the top or bottom of a shaft wall. As the long runner leg is continually flexed from wall deflection, it can rupture and screws can strip out and fracture from the flexing. Oscillation tests showed 24 ga. J-runners minimize these problems and are essential to long-term safety.

LIMITING HEIGHTS

Maximum partition heights are shown for four different intermittent air pressure loads and three allowable deflections. The applied pressure load is selected by the designer based on elevator cab speed and the number of elevators per shaft. Instead of using only deflection criteria, USG design data consider several additional factors in determining limiting partition heights:

- A. Bending stress—the unit force exerted that will break or distort the stud.
- B. End reaction shear—determined by the amount of force applied to the stud, which will bend or shear the J-runner or cripple the stud.
- C. Deflection—the actual deflection under a load. Allowable deflection is based on the amount of bending under load that a particular wall can experience without exceeding a prescribed ratio related to partition height.

ELEVATOR SHAFT PRESSURES

The air pressure load on shaft walls depends upon the elevator cab speed and the number of elevators per shaft. The following recommendations are derived from USG tests conducted in three high-rise buildings ranging in height from 17 to 100 stories.

Recommended Elevator Shaft Pressure Load		
Elevator velocity ft./min.	One or two elevators per shaft	Three or more elevators per shaft
0 to 180	5.0 psf	5.0 psf
180 to 700	7.5 psf	5.0 psf
700 to 1,600	10.0 psf	7.5 psf
1,600 to 2,000	15.0 psf ^a	7.5 psf



Note



(a) Single-cab, high-speed elevator shafts may require special design considerations.

PERFORMANCE SELECTOR

WALL SYSTEMS—LIMITING HEIGHTS TABLE



INTERMITTENT AIR
PRESSURE LOAD
(WIND LOAD)—PSF^a



Stud Type and Size	Designation	Allowable Deflection	One-Hour Shaft Wall / Stairwell (U415 System A) ^b				Two-Hour Shaft Wall (U415 System C) ^b			
			5	7.5	10	15	5	7.5	10	15
2-1/2" C-H Studs 	212CH25	L/120	11' 5"	10' 0"	9' 1" ^d	7' 11" ^d	—	—	—	—
		L/240	10' 7"	9' 3"	8' 4" ^d	7' 4" ^d	—	—	—	—
		L/360	9' 4"	8' 2"	7' 5"	6' 6"	—	—	—	—
	212CH20	L/120	13' 5"	11' 8"	10' 8"	9' 3"	—	—	—	—
		L/240	12' 3"	10' 9"	9' 9"	8' 6"	—	—	—	—
		L/360	10' 10"	9' 6"	8' 7"	7' 6"	—	—	—	—
4" C-H Studs 	400CH25	L/120	15' 2"	12' 5"	10' 9" ^d	8' 9" ^d	15' 2"	12' 5"	10' 9" ^d	8' 9" ^d
		L/240	14' 5"	12' 5"	10' 9" ^d	8' 9" ^d	14' 5"	12' 5"	10' 9" ^d	8' 9" ^d
		L/360	12' 9"	11' 2"	10' 1" ^d	8' 9" ^d	12' 9"	11' 2"	10' 1" ^d	8' 9" ^d
	400CH20	L/120	20' 5"	17' 10"	16' 2" ^d	13' 4" ^d	20' 5"	17' 10"	16' 2" ^d	13' 4" ^d
		L/240	17' 6"	15' 3"	13' 10"	12' 1" ^d	17' 6"	15' 3"	13' 10"	12' 1" ^d
		L/360	15' 3"	13' 4"	12' 1"	10' 7" ^d	15' 3"	13' 4"	12' 1"	10' 7" ^d
6" C-H Studs	600CH20	L/120	26' 3"	21' 5" ^d	18' 7" ^d	15' 2" ^d	26' 3"	21' 5" ^d	18' 7" ^d	15' 2" ^d
		L/240	24' 0"	21' 0" ^d	18' 7" ^d	15' 2" ^d	24' 0"	21' 0" ^d	18' 7" ^d	15' 2" ^d
		L/360	21' 1"	18' 5"	16' 9" ^d	14' 8" ^d	21' 1"	18' 5"	16' 9" ^d	14' 8" ^d
Double 6" E-Studs	600ES20	L/120	28' 0"	28' 0" ^d	28' 0" ^d	20' 0" ^d	28' 0"	28' 0" ^d	28' 0" ^d	20' 0" ^d
		L/240	28' 0"	24' 9"	22' 6" ^d	20' 0" ^d	28' 0"	24' 9"	22' 6" ^d	20' 0" ^d
		L/360	25' 3"	21' 9"	19' 6"	17' 3" ^d	25' 3"	21' 9"	19' 6"	17' 3" ^d

Stud Type and Size	Designation	Allowable Deflection	Two-Hour Shaft Wall (U415 System B, D, F)				Two-Hour Stairwell (U415 System E) ^c			
			5	7.5	10	15	5	7.5	10	15
2-1/2" C-H Studs 	212CH25	L/120	12' 4"	10' 10"	9' 10" ^d	8' 7"	12' 2"	10' 8"	9' 8" ^d	8' 5"
		L/240	11' 4"	9' 11"	8' 12" ^d	7' 10"	11' 2"	9' 9"	8' 10" ^d	7' 9"
		L/360	10' 4"	9' 1"	8' 3"	7' 2"	9' 10"	8' 7"	7' 10"	6' 10"
	212CH20	L/120	14' 3"	12' 5"	11' 4"	9' 11"	14' 2"	12' 5"	11' 3"	9' 10"
		L/240	12' 10"	11' 3"	10' 2"	8' 11"	13' 0"	11' 5"	10' 4"	9' 1"
		L/360	11' 7"	10' 1"	9' 2"	8' 0"	11' 6"	10' 0"	9' 1"	7' 12"
4" C-H Studs 	400CH25	L/120	17' 9"	14' 6"	12' 7"	10' 3" ^d	16' 4"	14' 3" ^d	12' 11" ^d	10' 7" ^d
		L/240	15' 7"	13' 8"	12' 5"	10' 3" ^d	15' 2"	13' 3" ^d	12' 0" ^d	10' 6" ^d
		L/360	13' 11"	12' 2"	11' 1"	9' 8" ^d	13' 4"	11' 8"	10' 7"	9' 3" ^d
	400CH20	L/120	19' 11"	17' 4"	15' 9"	13' 10" ^d	19' 6"	17' 1"	15' 6"	13' 7" ^d
		L/240	18' 1"	15' 9"	14' 4"	12' 6"	17' 11"	15' 8"	14' 3"	12' 5"
		L/360	16' 2"	14' 1"	12' 10"	11' 3"	15' 10"	13' 10"	12' 7"	10' 12"
6" C-H Studs	600CH20	L/120	25' 4"	22' 2"	19' 8" ^d	16' 1" ^d	28' 0"	25' 1" ^d	21' 9" ^d	17' 9" ^d
		L/240	21' 9"	19' 0"	17' 4"	15' 1" ^d	24' 10"	21' 9" ^d	19' 9"	17' 3" ^d
		L/360	20' 0"	17' 6"	15' 11"	13' 11"	21' 11"	19' 2"	17' 5"	15' 2"
Double 6" E-Studs	600ES20	L/120	28' 0"	28' 0" ^d	28' 0" ^d	20' 0" ^d	28' 0"	28' 0" ^d	28' 0" ^d	20' 0" ^d
		L/240	28' 0"	26' 3" ^d	24' 0" ^d	20' 0" ^d	28' 0"	26' 0" ^d	23' 6" ^d	20' 0" ^d
		L/360	26' 3"	23' 0"	21' 0" ^d	18' 3" ^d	25' 3"	22' 9"	20' 6"	18' 0" ^d

PERFORMANCE SELECTOR

WALL SYSTEMS—LIMITING HEIGHTS TABLE

Stud Type and Size	Designation	Allowable Deflection	Three-Hour Shaft Wall (U415 System G)				Three-Hour Stairwell (U415 System H) ^c			
			5	7.5	10	15	5	7.5	10	15
2-1/2" C-H Studs 	212CH25	L/120	12' 4"	10' 10"	9' 10"	8' 7"	12' 2"	10' 8"	9' 8"	8' 5"
		L/240	11' 4"	9' 11"	8' 12"	7' 10"	11' 2"	9' 9"	8' 10"	7' 9"
		L/360	10' 4"	9' 1"	8' 3"	7' 2"	9' 10"	8' 7"	7' 10"	6' 10"
	212CH20	L/120	14' 3"	12' 5"	11' 4"	9' 11"	14' 2"	12' 5"	11' 3"	9' 10"
		L/240	12' 10"	11' 3"	10' 2"	8' 11"	13' 0"	11' 5"	10' 4"	9' 1"
		L/360	11' 7"	10' 1"	9' 2"	8' 0"	11' 6"	10' 0"	9' 1"	7' 12"
4" C-H Studs 	400CH25	L/120	17' 9"	14' 6"	12' 7"	10' 3" ^d	16' 4"	14' 3" ^d	12' 11" ^d	10' 7" ^d
		L/240	15' 7"	13' 8"	12' 5"	10' 3" ^d	15' 2"	13' 3" ^d	12' 0" ^d	10' 6" ^d
		L/360	13' 11"	12' 2"	11' 1"	9' 8" ^d	13' 4"	11' 8"	10' 7"	9' 3" ^d
	400CH20	L/120	19' 11"	17' 4"	15' 9"	13' 10" ^d	19' 6"	17' 1"	15' 6"	13' 7" ^d
		L/240	18' 1"	15' 9"	14' 4"	12' 6"	17' 11"	15' 8"	14' 3"	12' 5"
		L/360	16' 2"	14' 1"	12' 10"	11' 3"	15' 10"	13' 10"	12' 7"	10' 12"
6" C-H Studs	600CH20	L/120	25' 4"	22' 2"	19' 8" ^d	16' 1" ^d	28' 0"	25' 1" ^d	21' 9" ^d	17' 9" ^d
		L/240	21' 9"	19' 0"	17' 4"	15' 1" ^d	24' 10"	21' 9" ^d	19' 9"	17' 3" ^d
		L/360	20' 0"	17' 6"	15' 11"	13' 11"	21' 11"	19' 2"	17' 5"	15' 2"
Double 6" E-Studs	600ES20	L/120	28' 0"	28' 0" ^d	28' 0" ^d	20' 0" ^d	28' 0"	28' 0" ^d	28' 0" ^d	20' 0" ^d
		L/240	28' 0"	26' 3" ^d	24' 0" ^d	20' 0" ^d	28' 0"	26' 0" ^d	23' 6" ^d	20' 0" ^d
		L/360	26' 3"	23' 0"	21' 0" ^d	18' 3" ^d	26' 3"	22' 9"	20' 6"	18' 0" ^d

Stud Type and Size	Designation	Allowable Deflection	Four-Hour Shaft Wall (U415 System I)			
			5	7.5	10	15
2-1/2" C-H Studs 	212CH25	L/120	12' 4"	10' 10"	9' 10" ^d	8' 7"
		L/240	11' 4"	9' 11"	8' 12" ^d	7' 10"
		L/360	10' 4"	9' 1"	8' 3"	7' 2"
	212CH20	L/120	14' 3"	12' 5"	11' 4"	9' 11"
		L/240	12' 10"	11' 3"	10' 2"	8' 11"
		L/360	11' 7"	10' 1"	9' 2"	8' 0"
4" C-H Studs 	400CH25	L/120	17' 9"	14' 6"	12' 7"	10' 3" ^d
		L/240	15' 7"	13' 8"	12' 5"	10' 3" ^d
		L/360	13' 11"	12' 2"	11' 1"	9' 8" ^d
	400CH20	L/120	19' 11"	17' 4"	15' 9"	13' 10" ^d
		L/240	18' 1"	15' 9"	14' 4"	12' 6"
		L/360	16' 2"	14' 1"	12' 10"	11' 3"
6" C-H Studs	600CH20	L/120	25' 4"	22' 2"	19' 8" ^d	16' 1" ^d
		L/240	21' 9"	19' 0"	17' 4"	15' 1" ^d
		L/360	20' 0"	17' 6"	15' 11"	13' 11"
Double 6" E-Studs	600ES20	L/120	28' 0"	28' 0" ^d	28' 0" ^d	20' 0" ^d
		L/240	28' 0"	26' 3" ^d	24' 0" ^d	20' 0" ^d
		L/360	26' 3"	23' 0"	21' 0" ^d	18' 3" ^d

Notes

- See the Performance Selector for system references and rated assembly details.
- Runner fasteners should withstand 193 lb. single shear and 200 lb. bearing force; attachment spacing should not exceed 24".
- L/180 deflection information available upon request from USG.
- (a) Stud spacing of 24" o.c.
- (b) For assembly single-layer board attached to studs.
- (c) For assembly with single-layer board attached to both sides of studs.
- (e) Attachment of USG steel double 6" E-Stud for USG Shaft Wall Systems. The studs are to be attached back-to-back (web-to-web) with pairs of 1/2" long Type S-12 pan head screws installed in two rows, spaced as widely apart as possible. The first and last pairs of fasteners shall start within 6" of each end of the studs. They shall then be spaced at a maximum of 12" o.c.

Limiting Criteria

- c - practical limitation
- d - deflection
- f - bending
- v - end reaction shear

PERFORMANCE SELECTOR



WALL SYSTEMS—LIMITING HEIGHTS

UNLINED SHAFTS

Gypsum shaft walls have been used for many years for vent and air shafts. Their fire-resistant features and economical dry construction make them ideal for this use. To function properly, vent and air shaft systems should be designed with the following performance provisions:

1. Gypsum board surface temperature does not exceed 125°F.
2. Separate approved liners should be installed in areas subject to continuous moisture overspray, condensation or air stream temperature over 125°F.
3. Air stream dew point temperatures are maintained below gypsum board surface temperature.
4. The assembly is constructed to withstand sustained design uniform air pressure loads not exceeding 10 psf. Startup surge loads should not be greater than 1-1/2 times the design static load. (See table below for limiting heights.)
5. To ensure airtight construction, select appropriate sealants and apply where required.

SUSTAINED PRESSURE LOAD—PSF

Stud Type and Size	Designation	Stud Spacing	Allowable Deflection	Two-Hour Fire-Rated System		One-Hour Fire-Rated System	
				5	10	5	10
 2-1/2" C-H Studs	212CH-18	24"	L/120	10' 10"	8' 7"	10' 0"	7' 11"
			L/240	9' 11"	7' 10"	9' 3"	7' 4"
			L/360	9' 1"	7' 2"	8' 2"	6' 6"
	212CH-34	24"	L/120	12' 5"	9' 11"	11' 8"	9' 3"
			L/240	11' 3"	8' 11"	10' 9"	8' 6"
			L/360	10' 1"	8' 0"	9' 6"	7' 6"
 4" C-H Studs	400CH-18	24"	L/120	14' 6"	10' 3"	12' 5"	8' 9"
			L/240	13' 8"	10' 3"	12' 5"	8' 9"
			L/360	12' 2"	9' 8"	11' 2"	8' 9"
	400CH-34	24"	L/120	17' 4"	13' 10"	17' 10"	13' 4"
			L/240	15' 9"	12' 6"	15' 3"	12' 1"
			L/360	14' 1"	11' 3"	13' 4"	10' 7"
6" C-H Studs	600CH-34	24"	L/120	22' 2"	16' 1"	21' 5"	15' 2"
			L/240	19' 0"	15' 1"	20' 12"	15' 2"
			L/360	17' 6"	13' 11"	18' 5"	14' 8"

For more information, consult Progressive Engineering Report AER-09038 at p-e-i.com

Notes

Runner fasteners should withstand 193 lb. single shear and 200 lb. bearing force; attachment spacing should not exceed 24" o.c.
 (a) Use JR20 runner for this height.

PERFORMANCE SELECTOR

WALL SYSTEMS—SOLID SHAFT WALL

USG Shaft Wall Systems can be used as a vent enclosure for vertical shafts with a two-hour fire rating per UL Design U529. This shaft assembly is particularly suited for structures having a number of relatively small and separated mechanical, service and ventilator shafts.

Vent Shaft Elevation

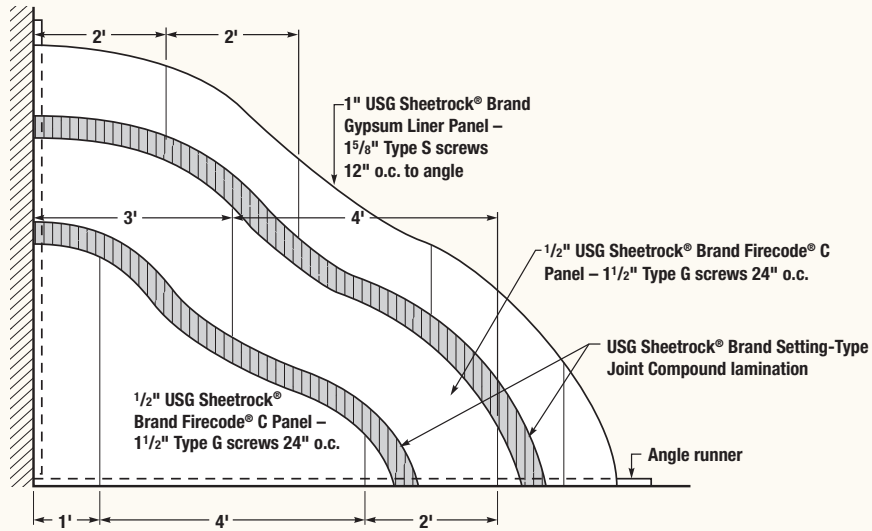

Wall Intersection

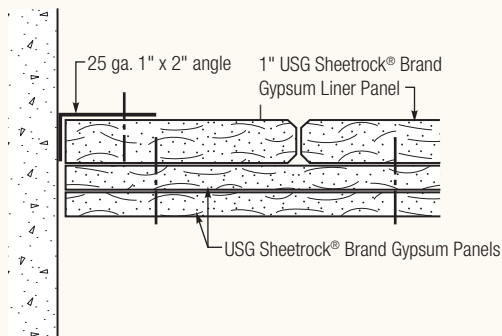

Corner

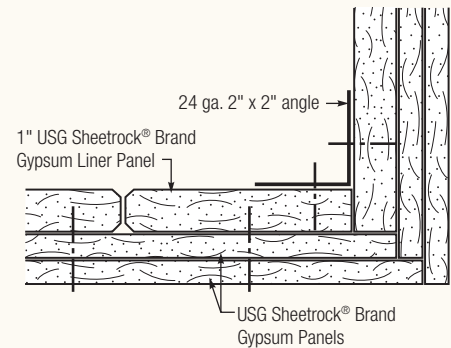

Note
Limiting height of system is 12' 0". Install panels vertically and full height only.

PERFORMANCE SELECTOR

CEILING SYSTEM—LIMITING SPANS

HORIZONTAL ASSEMBLIES

USG Shaft Wall Systems installed horizontally provide economical construction for fire-resistive duct enclosures, corridor ceilings and stairway soffits.

Triple Layer: With 1" liner panels inserted in USG C-H studs 24" o.c. and triple-layer 1/2" USG Sheetrock® Brand Firecode® C Panels screw-attached to studs, the system provides two-hour protection from fire. This system is limited to a maximum span of 5'-4". For larger spans, use the "Two-Hour Rated Duct Enclosure (UL Design K504 and K506)" detail as shown on page 24.

Double Layer: With double-layer 1/2" USG Sheetrock® Brand Firecode® C Panels screw-attached to studs, the assembly provides two-hour fire-resistive ceiling construction for corridors and stair soffits (see design details).

Single Layer: With single-layer 5/8" USG Sheetrock® Brand Firecode® X or C Panels screw-attached to studs, the assembly provides one-hour fire-resistive ceiling construction for corridors and stair soffits.

Limitations

1. USG C-H studs are not designed to carry live loads or mechanical equipment or provide material storage area.
2. Maximum stud spacing is 24" o.c.; maximum spans are shown in table below.

LIMITING SPANS—HORIZONTAL SHAFT WALLS

One-Hour Exit Corridor Ceiling and Stair Soffits		Two-Hour Exit Corridor Ceiling and Stair Soffits	
Single-Layer 5/8" Gypsum Panels ^c	Maximum Span	Double-Layer 1/2" Gypsum Panels ^c	Maximum Span
212CH25-18	8' 6"	212CH25-18	7' 10"
212CH20-34	10' 4"	212CH20-34	9' 8"
400CH25-18	9' 3"	400CH25-18	7' 7"
400CH20-34	14' 11"	400CH20-34	14' 0"
600CH20-34	20' 10"	600CH20-34	19' 7"

For more information, consult Progressive Engineering Report AER-09038 at p-e-i.com

DESIGN DETAILS

CEILING MEMBRANE

Two-Hour Rated Assembly – Horizontal Membrane or Metal Duct Enclosure

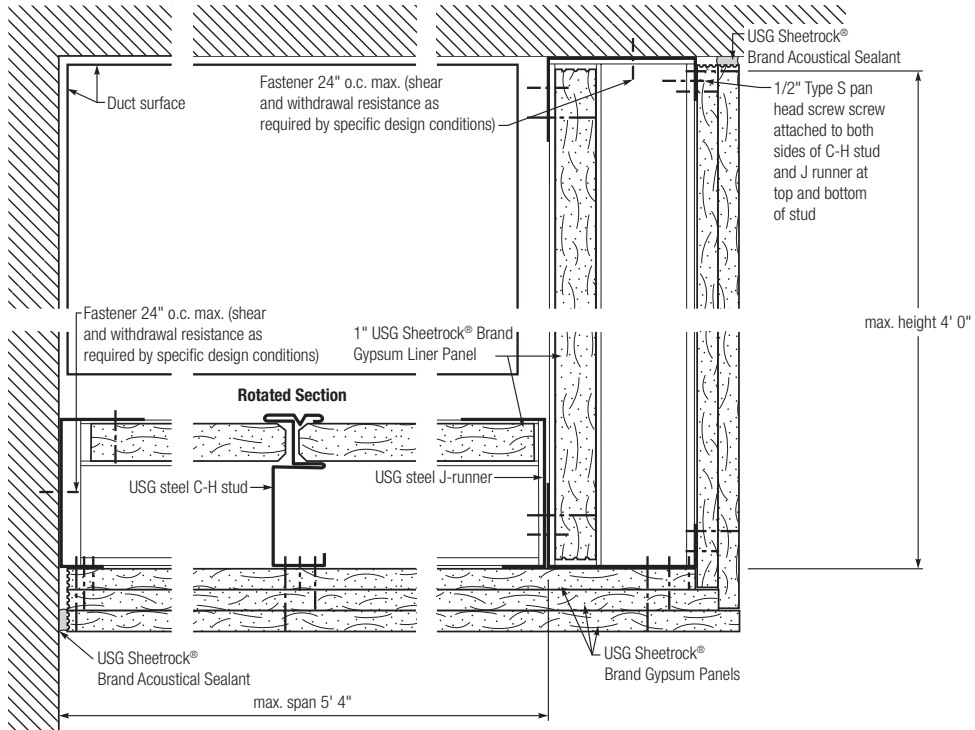

For more information consult Progressive Engineering Report AER-09038 at p-e-i.com. For spans greater than 5' 4", see UL Design K504 and K506, per details on page 24.

Ceiling Membrane of One-Hour Egress Corridors and Stair Soffits (see AER-09038)

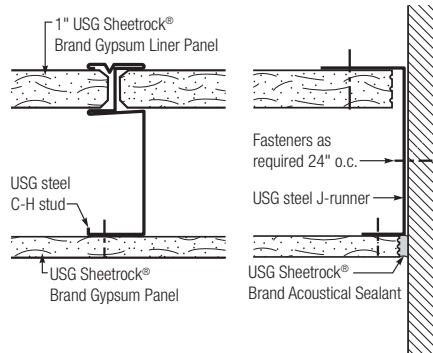

Refer to span table on page 22.

Ceiling Membrane of Two-Hour Egress Corridors and Stair Soffits (see AER-09038)

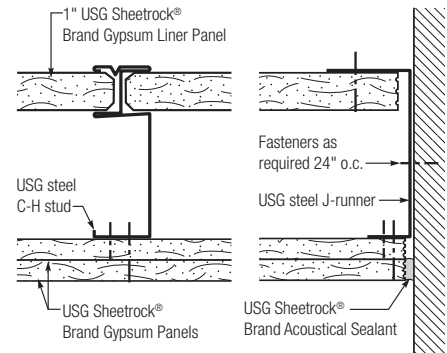

Refer to span table on page 22.

DESIGN DETAILS

CEILING MEMBRANE

Two-Hour Duct Enclosure (UL Design K506)

Vertical assembly shown is UL Design U415 System B.

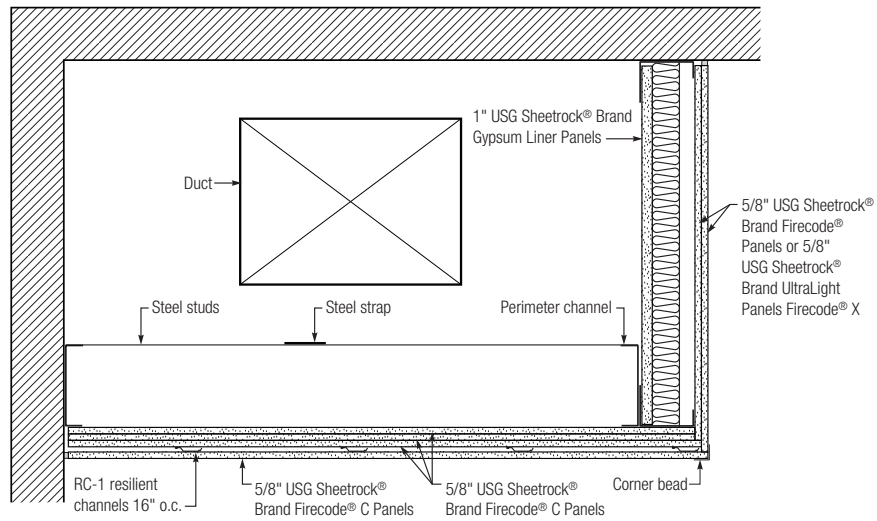

Two-Hour Rated Ceiling Membrane Assembly (UL Design K504)

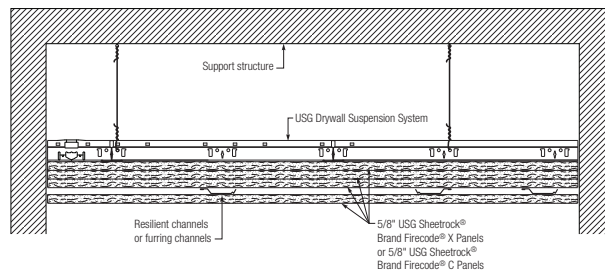

Two-Hour Rated Ceiling Assembly (UL Design K506)

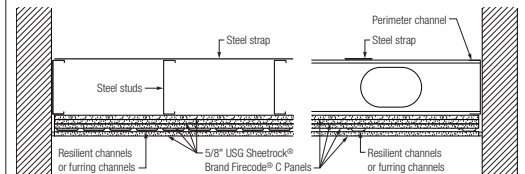

DESIGN DETAILS

BASIC INTERFACES—SYSTEM B

Head Section (UL System HW-D-0603)

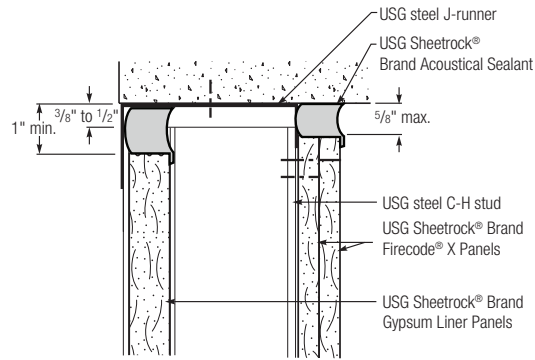

Base Section (UL System BW-S-0016)

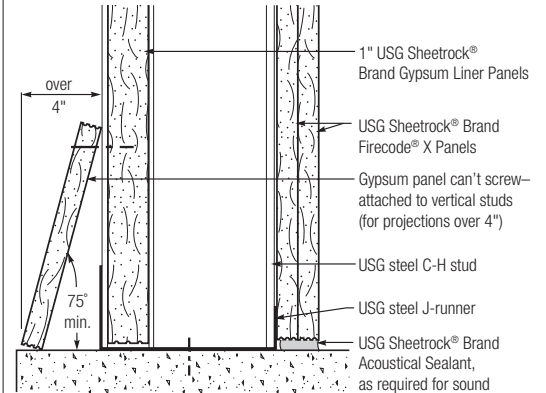

Call-Button Box

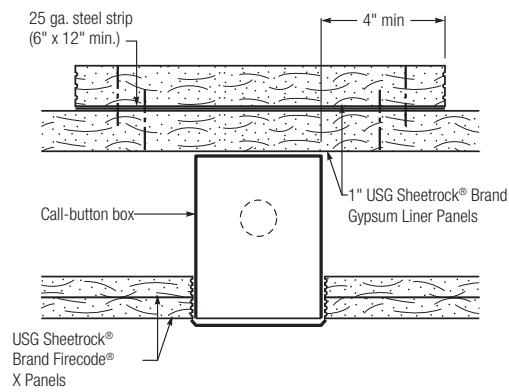

DESIGN DETAILS

BASIC INTERFACES—SYSTEM B

Wall Junction

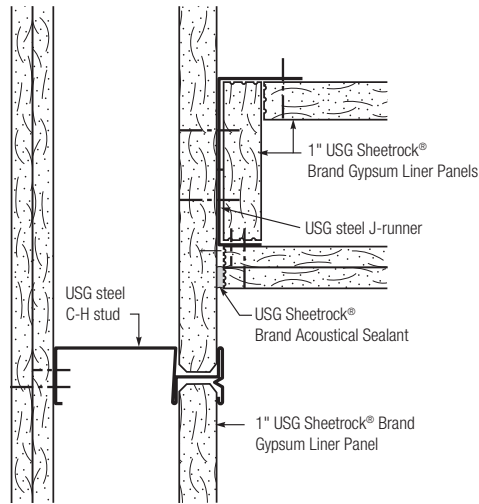

Outside Corner

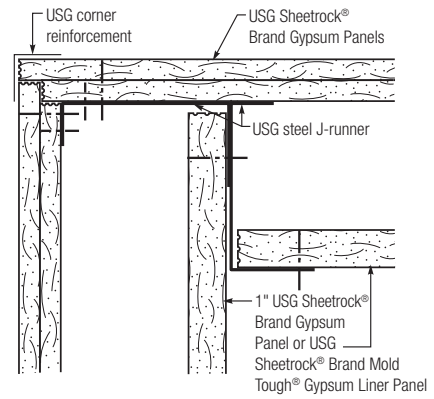

Wall Intersection

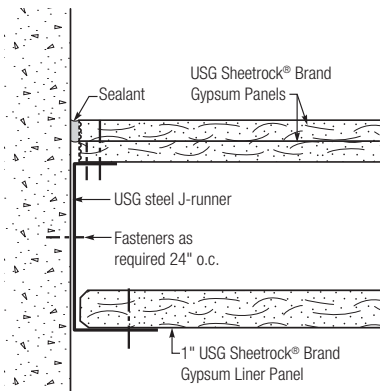

Inside Corner

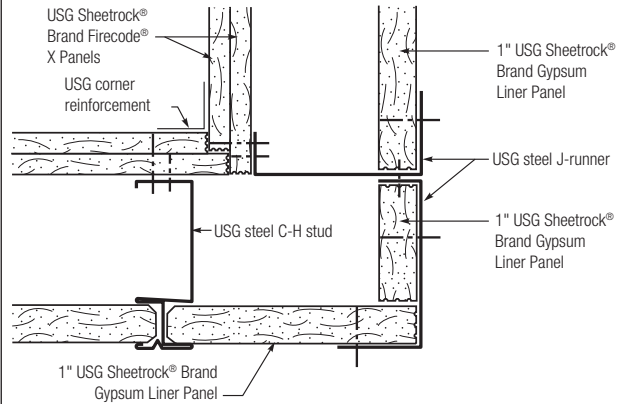

DESIGN DETAILS

BASIC INTERFACES—SYSTEM B

Outlet/Switch Box

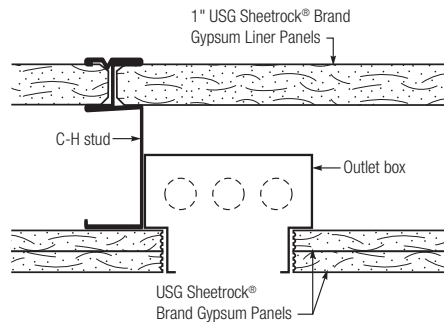

Control Joint in Two-Hour Shaft Walls

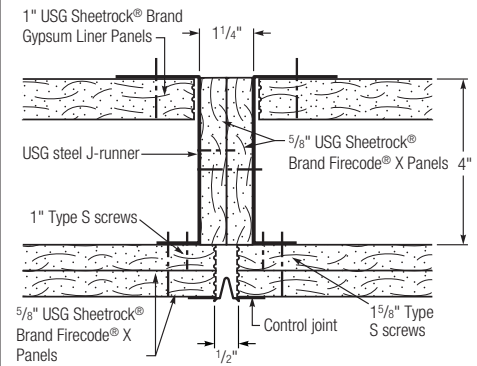

Stair Hanger and Rod Application

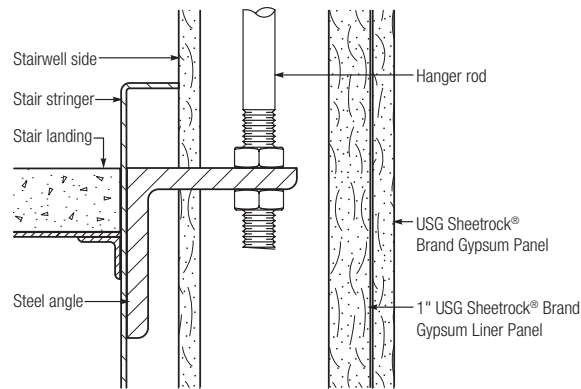

Cross-Section at Stair Hanger

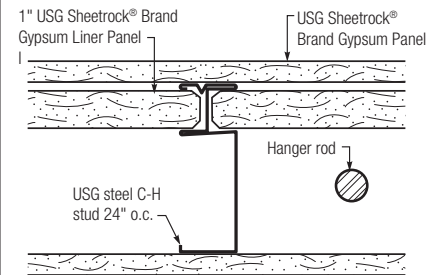

DESIGN DETAILS

BASIC INTERFACES—SYSTEM B

Handrail Application

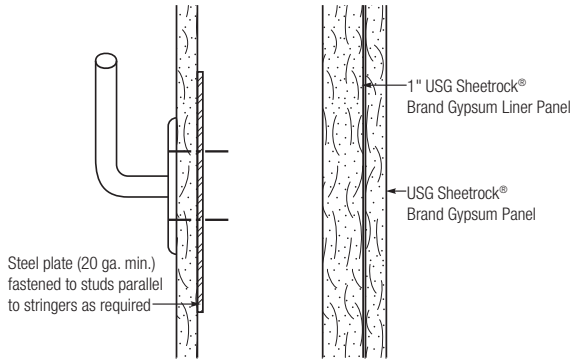

Steel Beam (UL System HW-D-0610)

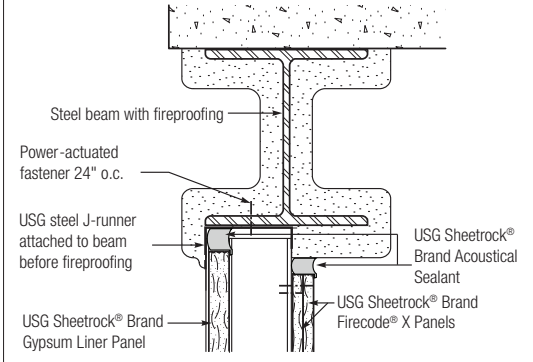

Steel Beam with Z-Clip (UL System HW-D-0609)

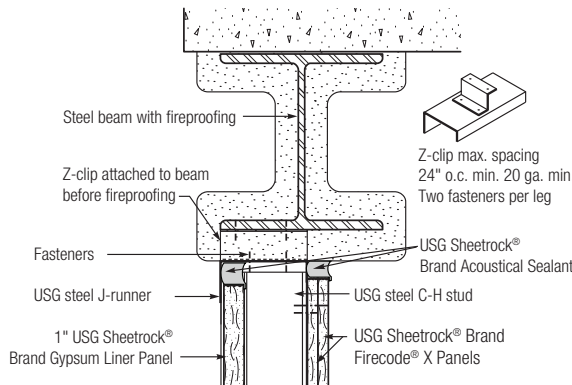

Steel Beam with Offset (UL System HW-D-0611)

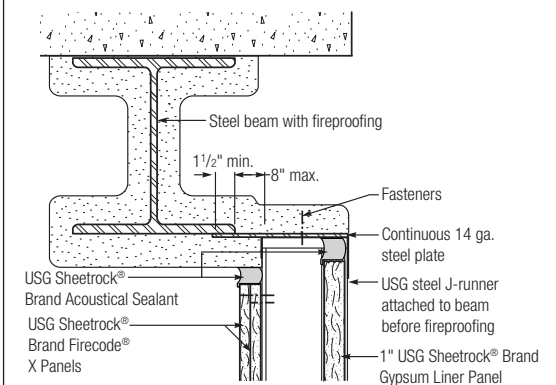

DESIGN DETAILS

FIRE DAMPER

Typical Duct Opening Penetration (See Damper and Duct Manufacturer Installation Instructions for Further Details)

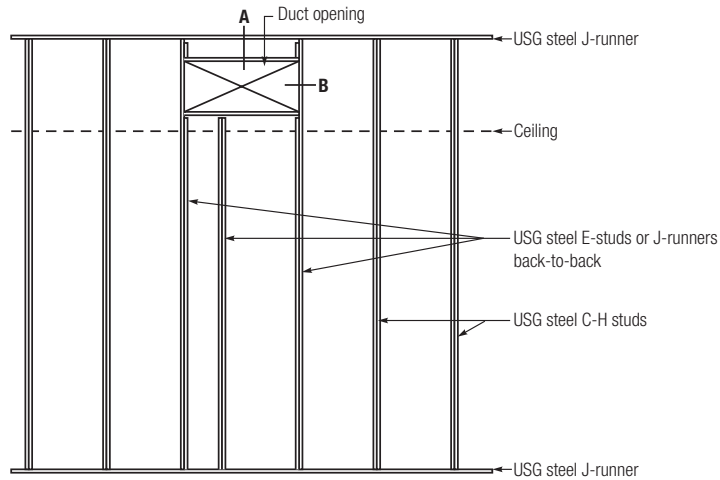

Section A: Fire Damper Installation (See Damper and Duct Manufacturer Installation Instructions for Further Details)

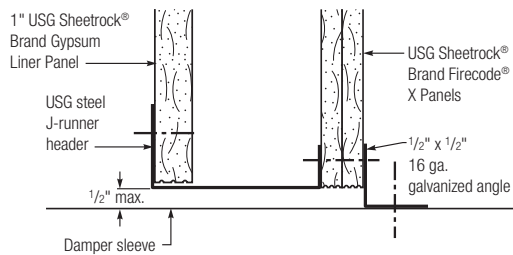

Section B: Fire Damper Installation (See Damper and Duct Manufacturer Installation Instructions for Further Details)

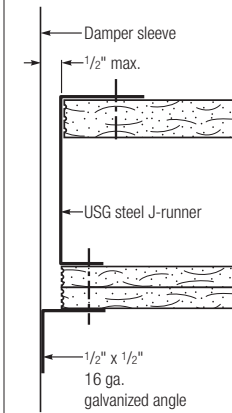

DESIGN DETAILS

ELEVATOR DOOR FRAMING

ELEVATOR DOOR FRAMING

Elevator Door Rough Opening

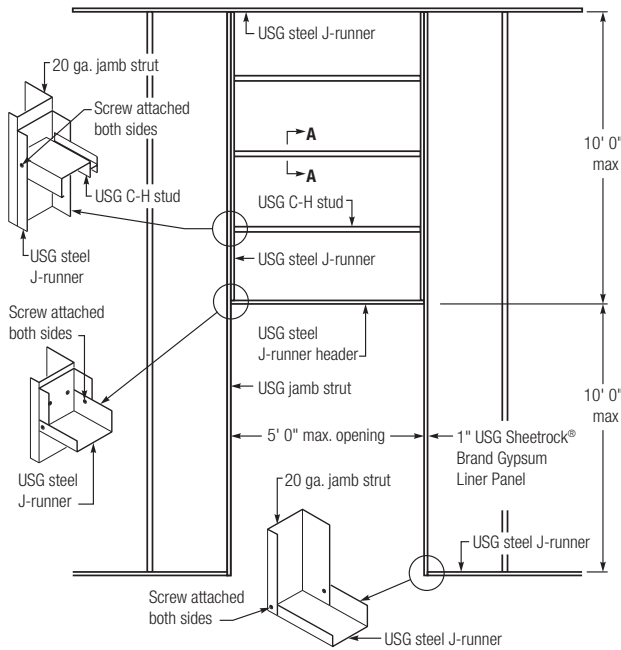

Section A-A Detail

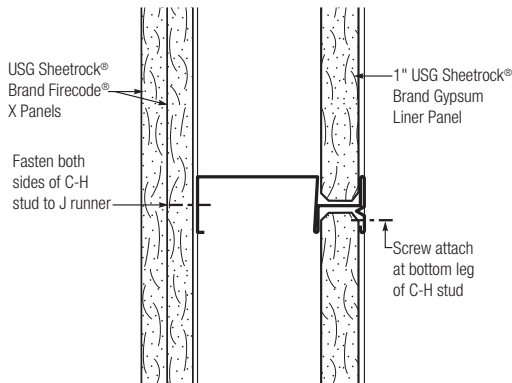

Notes

1. Framing at elevator door shall be a minimum 4" studs and runners 20 gauge.
2. Horizontal placement of liner panel and C-H studs per UL Design U437.
3. Flanges of the jamb strut must be continuously braced by screw connections to the liner and face panels 12" o.c.
4. For doors greater than 5' wide and or transom heights greater than 4', reinforce the 400JS-34 with a nested 400ES-34.

DESIGN DETAILS

WALL SYSTEMS—C-H STUDS AND LINER PANELS INSTALLED HORIZONTALLY

Horizontal Stud Shaftwall

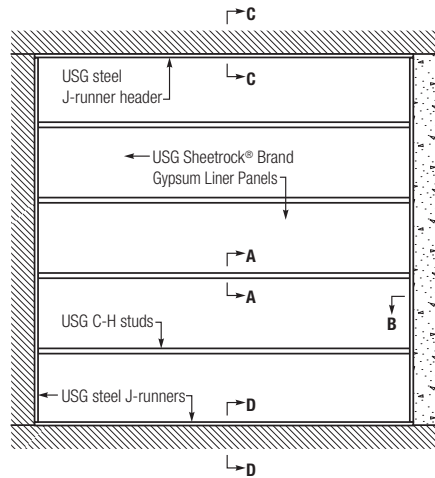

Section C-C Head Section

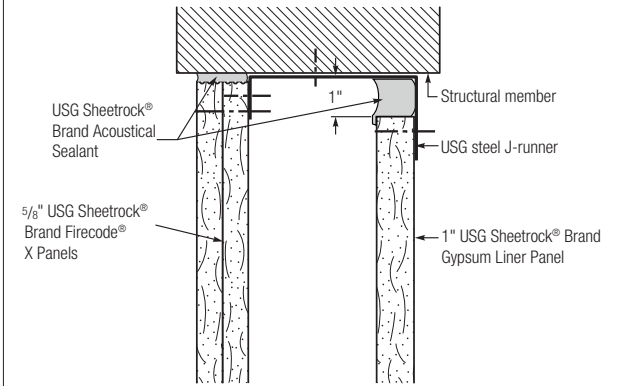

Section B-B Wall Intersection

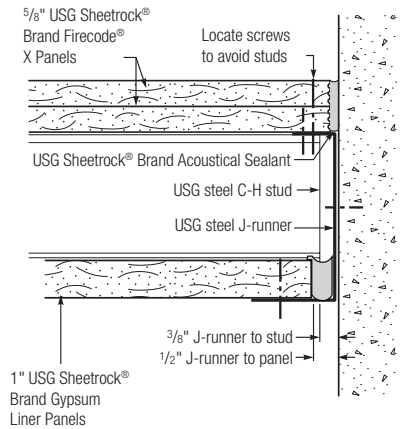

Section D-D Base Section

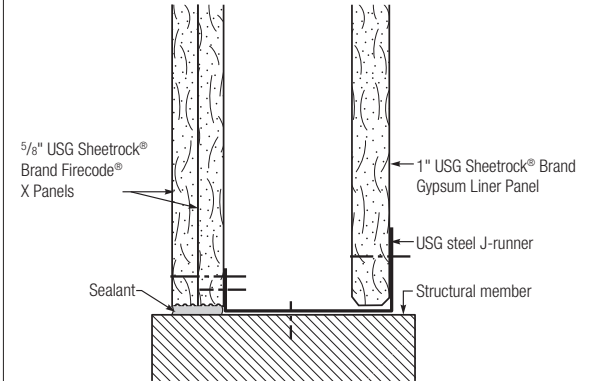

Note

Horizontal framing shall be a minimum 4" C-H studs and runners 20 gauge.

GOOD DESIGN PRACTICES

Use this section as a reference if questions arise during the design or application of USG Shaft Wall Systems.

This section is an overview of good design, application, installation and safety considerations that should be addressed when USG products and systems are used. This section outlines some major issues but is not intended to be comprehensive.

We recommend that architects and contractors seek the assistance of safety professionals, especially at the construction site, because there are many factors to consider that are not included here. For more detailed information on safety and material handling, please refer to *The Gypsum Construction Handbook*.

1 SYSTEM PERFORMANCE

USG conducts tests on products and systems to meet performance requirements specified by various agencies. Upon written request we will provide test certification for published fire, sound, structural and other pertinent data covering systems designed and constructed according to our published specifications. Substitutions of any of the components are not recommended and are not supported by USG.

Standards

The following standards apply:

ASTM C1396: Standard Specification for Gypsum Board

ASTM C1658: Standard Specification for Glass-Mat Gypsum Panels

ASTM C1325: Standard Specification for Non-Asbestos Fiber-Mat Reinforced Cementitious Backer Units

ASTM C1278: Standard Specification for Fiber-Reinforced Gypsum Panel

ASTM C840: Standard Specification for Application and Finishing of Gypsum Board

ASTM C754: Standard Specification for Installation of Steel Framing Members to Receive Screw-Attached Gypsum Board, Backing Board, or Water-Resistant Backing Board

ASTM C645: Standard Specification for Non-Load (Axial) Bearing Steel Studs, Runners (Track), and Rigid Furring Channels for Screw Application of Gypsum Board

ASTM C475: Standard Specification for Joint Treatment Materials for Gypsum Wallboard Construction

ASTM C1002: Standard Specification for Steel Drill Screws for the Application of Gypsum Board

ASTM C1047: Standard Specification for Accessories for Gypsum Wallboard and Gypsum Veneer Base

ASTM D3273: Standard Test Method for Resistance to Growth of Mold on the Surface of Interior Coatings in an Environmental Chamber

2 FIRE RESISTANCE

Use fire test data to compare and select materials and assemblies, and to secure acceptance by the authority having jurisdiction. *Fire-Resistant Assemblies* (SA100) shows tested fire resistance for various systems.

For assemblies tested at UL, ratings are specific to the designs tested and do not necessarily apply to alternate products or construction. For example, insulation may not be added to floor- or roof-ceiling assemblies, unless described in the UL design. Addition of insulation in the concealed space between the ceiling membrane and the floor or roof structure may reduce the hourly rating of an assembly by causing premature disruption of the ceiling membrane and/or higher temperatures on structural components under fire exposure conditions.

Increasing the size or gauge of the stud (e.g., 2-1/2" C-H stud 25 gauge to 4" C-H stud 20 gauge) does not affect the fire resistance rating of the assembly.

For more detailed information, refer to the system fire resistance Performance Selector on pages 14-15.

GOOD DESIGN PRACTICES

3 STRUCTURAL CRITERIA

Building structure supporting USG Shaft Wall System must be capable of withstanding the loads applied by shaft wall assemblies.

Interior non-bearing partitions such as USG Shaft Wall are not designed to carry axial loads. Limiting heights are based on stress or deflection limits for lateral loads specified in the Performance Selector of this guide. Height limitations depend on the gauge of the steel used, dimensions of the stud, stud spacing and the allowable deflection limit. For limiting height tables, see page 17; for horizontal shaft wall span table, see page 20; and for limiting heights, unlined return air shafts, see page 18.

Note: Size and gauge of the studs are specified in the limiting heights tables. Other sizes and gauges have not been evaluated for performance.

4 CONTROL JOINTS— BUILDING MOVEMENT

Locating control joints is the responsibility of the design professional/architect. Integrate these suggestions with project conditions when determining specific locations for control joints.

“Control joint” is a general term for methods used to minimize (not eliminate the potential for) cracking in partitions and ceilings. Specifically, a control joint minimizes cracking in the face of a partition or ceiling. At the perimeter of a partition or ceiling, it is called a perimeter relief joint.

A control joint is effective in minimizing cracking caused by tensile or compressive movement in a membrane resulting from thermal, hygrometric and structural movement. Isolate shaft wall surfaces with control joints or other means where:

- Construction changes within the plane of the shaft wall
- Shaft wall run exceeds 30'
- Expansion or control joints occur through the building itself
- In stairwells at each floor level

Ceiling-height door frames may be used as control joints. Less-than-ceiling-height door frames should have control joints extending to ceiling from both corners on both sides of the partition. Treat window openings in same manner as doors.

Zinc control joints, when properly insulated and backed by gypsum panels, have been fire-endurance tested for use in one- and two-hour fire-rated walls.

Proper installation of control joints in partitions and ceilings requires breaking the gypsum panels or lath behind the control joint. In ceiling construction, the framing should also be broken. In partitions, separate studs are used on each side of the joint with the runner track separated at that location.

5 PRESSURE LOADS— MINIMIZING WIND NOISE

Where shaft walls enclose elevator and return air vents and intermittent pressures up to 15 psf are expected, USG Sheetrock® Brand Acoustical Sealant is recommended at intersections with floors, ceilings, columns, ducts, etc. to seal peripheries and penetrations and minimize whistling and dirt accumulation due to air movement. Sealant selection including joint treatment, surface coatings and details to seal the wall under these sustained pressures must be provided by the designer. See pages 16-17 for information on evaluating pressure loading and selecting the appropriate framing components based upon these design criteria.

6 PRESSURE LOADS— AIR HANDLING

Shaft walls may be used for air handling with sustained pressures up to 10 psf. When air pressure exceeds 10 psf, air handling should be contained with a metal duct. See pages 18-19 for information about air handling and vent shaft enclosures.

GOOD DESIGN PRACTICES

7 PENETRATIONS

Penetrations of the shaft wall, such as door frames and duct openings, require additional reinforcement at corners to distribute concentrated stresses if a control joint is not used. Penetrations greater than 48" wide require supplemental support for the shaft wall at the opening. Where there are access panels or large duct penetrations, pressure loads, headers, sills and adjacent channels may require reinforcing to properly distribute these loads.

8 SOUND CONTROL

Use sound test data to compare and select materials and constructions. These data frequently are essential for securing compliance by the agency having jurisdiction. See *Acoustical Assemblies* (SA200) for acoustical performance.

Sound control refers to the ability to attenuate sound passing through a partition. The STC is a widely used rating of sound attenuation performance. It is relatively accurate for speech sounds but not for music, mechanical equipment noise or any sound with substantial low-frequency energy. It is tested per ASTM E90 and rated per ASTM E413. See the Performance Selector for the STC ratings for USG Shaft Wall Systems.

Sound tests are conducted under ideal laboratory conditions per ASTM procedures. USG products are assembled in a specific manner to meet the requirements of these ASTM procedures. Substitution of materials other than those tested or deviation from the specified construction may adversely affect performance.

Field performance depends on building design and careful attention to detailing and workmanship. Where these partitions are used for sound control, seal the partition perimeter with 1/4" min. round bead of USG Sheetrock® Brand Acoustical Sealant. Seal around all penetrations.

9 MOISTURE AND MOLD

Understanding water and mold and its impact on the construction process and building materials are integral to good design and construction practices. USG offers references and additional sources that reinforce good design, construction and maintenance practices. These practices are generally recognized as necessary to minimize moisture-related problems and the growth of mold in a building environment. If you have additional questions, please contact those sources or USG.

The best way to address mold is to make sure that building materials do not get wet before and during installation and are not exposed to moisture inside the finished building. See Moisture/Mold in the Performance Testing section for more information.

10 AIR AND WATER INFILTRATION

Flashing and sealants as shown in the construction documents and as selected by the architect and/or structural engineer should be provided to resist air and water infiltration. The flashing and sealants selected shall be installed in a workmanlike manner in appropriate locations to maintain continuity of air/water barriers, particularly at windows, doors and other penetrations of exterior wall.

11 VAPOR RETARDERS

Water vapor control must always be considered in the design of exterior wall systems. Humidity and temperature conditions may require the installation of a vapor retarder to prevent moisture condensation within the wall and the resulting damage. To determine the necessity and location of vapor retarders, a water vapor transmission and dew point analysis of the layered wall assembly should be conducted by a qualified engineer.

GOOD DESIGN PRACTICES

12 PRODUCT HANDLING AND STORAGE

Gypsum Panels: Protect all gypsum products from exposure to excessive or continuous moisture and the elements before, during and after installation. Eliminate sources of moisture immediately.

Metal Framing Protection: Give light-gauge metal components such as steel studs and runners, furring channels and resilient channels adequate protection in the warehouse and on the job site against rusting caused by moisture. In marine areas such as the Caribbean, Florida and the Gulf Coast where chloride and sea salt are present in combination with excessively high humidity, use of components that offer increased protection against corrosion is recommended.

13 APPLICATION

Call-Button Floor Indicator and Electric Boxes: Shaft walls will accommodate outlet boxes with depths up to the stud width. See page 25 for details.

Framing Attachment: Runners and studs attached to beams or columns may need to be installed before steel is spray-fireproofed. Excess fireproofing should be removed from runners and studs before installing shaft wall liner and sealant.

USG Sheetrock® Brand Gypsum Liner Panel Application—Butt Joints: When an installation of USG Shaft Wall height exceeds maximum available panel length, it is necessary to incorporate a butt joint between two liner panels. Stagger butt joints in adjacent panels top and bottom to prevent a continuous horizontal joint. Joint should be located in top or bottom third of wall. Horizontal joints need not be backed by steel framing to maintain the fire rating of the assembly.

14 PAINTING SYSTEMS

Painting products and systems should be used that comply with recommendations and requirements in appendices of ASTM C840. For priming and decorating with paint, texture or wall covering, follow manufacturer's directions.

All surfaces, including applied joint compound, must be thoroughly dry, dust-free and not glossy. Prime with USG Sheetrock® Brand First Coat™ Primer or with an undiluted, interior latex flat paint with high-solids content. Allow to dry before decorating.

To improve fastener concealment, where gypsum panel walls and ceilings will be subjected to severe artificial or natural side lighting and decorated with a gloss paint (eggshell, semigloss or gloss), the gypsum panel surface should be skim coated with joint compound to equalize suction and texture differences between the drywall face paper and the finished joint compound before painting. USG Sheetrock® Brand Tuff-Hide™ Primer-Surfacer skims and primes in a single application.

15 SCREWS

USG Durock™ Brand Fasteners for Steel Framing:

USG Durock™ Brand Tile Backer Screws for steel framing Type G screws; 1-5/8", 1-1/4".

USG Fiberock® Panel Fasteners for Steel Framing:

Use corrosion-resistant Type S-12 buglehead screws for 20-12 ga. steel framing. When using 20 ga. steel framing, fasteners should be spaced no greater than 8" o.c. Fasteners must be of sufficient length to ensure a minimum of 3/8" penetration into steel framing.

16 STEEL DOOR FRAMES

Ordered separately, should be at least 16 ga. steel, shop primed and have throats accurately formed to overall thickness of the shaft wall plus 3/32" minimum. They should be anchored at floor with 16 ga. steel plates welded to trim flanges, with provision for two power-driven anchors or equal per plate. Jamb anchors should be 18 ga. steel welded in jamb and screw-attached to anchors.

USG reserves the right to make changes or improvements in the design of all catalogued items without notice and without obligation to incorporate these changes or improvements in items already manufactured.

APPLICATION GUIDE SPECIFICATIONS

This guide specification is provided to assist you in specification of USG Shaft Wall Systems. If you have additional questions or would like more information regarding this or other USG products and systems, please contact USG at 800 USG.4YOU (874-4968) or visit usgdesignstudio.com

PART 1: GENERAL

1.1 RELATED DOCUMENTS

Drawings and general provisions of the project contract, including General and Supplementary Conditions and Division 1 Specification Sections, apply to this Section. USG System Folder SA926—USG Shaft Wall Systems.

1.2 SCOPE

Specify the appropriate USG Shaft Wall System to meet project requirements for fire resistance, structural performance, sound control and aesthetics.

1.3 SUMMARY

- A. This section includes the following USG Shaft Wall Systems
 1. Vertical shaft enclosures
 2. Stair enclosures
 3. Horizontal assemblies
 4. Vent shaft enclosures
 - B. Related Sections:
 1. Division 9 USG Sheetrock® Brand Gypsum Panels and assemblies
 2. Division 9 USG Imperial® Gypsum Base and Veneer Plaster Assemblies
-

1.4 DEFINITIONS

- A. Shaft Wall: An assembly of steel framing, gypsum boards and other materials used to enclose elevator shafts, stairways, air shafts and mechanical components.
 - B. Gypsum Board Construction Terminology: Refer to ASTM C11 for definition of terms for gypsum board construction not defined in this document.
-

1.5 PERFORMANCE REQUIREMENTS

- A. The systems are UL Listed for fire resistance.
 - B. System fire-resistance testing with elevator door manufacturer at UL.
 - C. Fire resistance tested penetration details for call-button boxes and position indicators.
 - D. Oscillation tested to 1 million cycles to ensure performance of the life of the building.
 - E. UL Listed fire damper application.
 - F. **Air Pressure Loads**—Select based on project requirements. See details in this brochure for USG Shaft Wall System data.
 - G. **Deflection Limit**—Select based on project requirements. See details in this brochure for USG Shaft Wall System data.
 - H. **STC Rating**—Select based on project requirements.
 - I. **Hardened Shafts**—Where required by code, for buildings classified as high-rise buildings, special provisions may be required.
-

1.6 SUBMITTALS

- A. Product and System Data—Submit USG System Folder SA926, which can be downloaded at usg.com.
- B. Submit certification of manufacturer compliance with fire and sound requirements indicated.
- C. Fire-rating compliance shall include verification of compatibility with labeled elevator door frame installation and test verification of call box and similar penetrations.

APPLICATION GUIDE SPECIFICATIONS

1.7 DELIVERY, STORAGE AND HANDLING OF MATERIALS

- A. Deliver materials in their original unopened packages bearing manufacturer identification.
 - B. Protect materials from wetting and damage from weather, direct sunlight, surface contamination, corrosion, construction traffic and other causes.
 - C. **Warning:** Store all USG Sheetrock® Brand Gypsum Panels flat. Panels are heavy and can fall over, causing serious injury or death. Do not move unless authorized.
-

1.8 PROJECT CONDITIONS

- A. All materials shall be suitably protected from the weather during installation to prevent damage to the shaft wall.
 - B. Install gypsum panels following environmental conditions, room temperatures and ventilation specified in *The Gypsum Construction Handbook*.
-

1.9 QUALITY ASSURANCE

- A. Protect USG Shaft Wall System and components from moisture before, during and after installation. Eliminate sources of moisture immediately.
 - B. Fire-Resistance-Rated Assemblies: Provide UL Design Number (e.g., U415) for basic systems.
 - C. **Sound-Rated Assemblies (STC)**—Provide sound-rated system whose materials and construction comply with requirements of ASTM E90 and are classified according to ASTM E413 by a qualified testing agency.
 - D. Preinstallation Conference—Conduct conference at project site. Review methods and procedures for work related to USG Shaft Wall System assemblies.
-

PART 2: PRODUCTS

2.1 MANUFACTURER

- A. Supply materials manufactured by or for the United States Gypsum Company that comply with requirements of fire resistance-rated assemblies indicated in USG System Folder SA926.
 - B. **Basis of Design**—USG Shaft Wall System
-

2.2 MATERIALS

- A. **Gypsum Liner Panels**—ASTM C1396, 1" USG Sheetrock® Brand Gypsum Liner Panels, 100% recycled green face and back paper, beveled edge, 24" wide, lengths as required. Stamped with UL Classification label documenting UL Classifications for fire resistance, surface burning characteristics and noncombustibility. Panels should also be identified with the following language: "USG Sheetrock® Brand Gypsum Liner Panel, a Component of United States Gypsum Company Fire-Rated Systems."
- B. **USG Sheetrock® Brand Mold Tough® Gypsum Liner Panels**—ASTM C1396, 1" USG Sheetrock® Brand Mold Tough® Gypsum Liner Panels, 100% recycled blue face and back paper, beveled edge, 24" wide, lengths as required. Stamped with UL Classification label documenting UL Classifications for fire resistance, surface burning characteristics and noncombustibility. Panels should also be identified with the following language: "USG Sheetrock® Brand Mold Tough® Gypsum Liner Panel, a Component of United States Gypsum Company Fire-Rated Systems."
- C. **USG Sheetrock® Brand Glass-Mat Liner Panels**—ASTM C1658, 1" USG Sheetrock® Brand Glass-Mat Liner Panels, moisture- and mold-resistant gypsum core encased in a moisture- and mold-resistant glass mat on both sides, 24" wide, lengths as required. Stamped with UL Classification label documenting UL Classifications for fire resistance, surface burning characteristics and noncombustibility. Panels should also be identified with the following language: "USG Sheetrock® Brand Glass-Mat Liner Panel, a Component of United States Gypsum Company Fire-Rated Systems."
- D. **Gypsum Wallboard**—ASTM C1396, (1/2") (5/8") (3/4") (select thickness), 4' wide, tapered edge, USG Sheetrock® Brand Gypsum Panels, (Firecode® X) (Firecode® C) (Ultracode® Core) (Mold Tough® Firecode® X), ASTM C1287 (USG Fiberock® Aqua-Tough™ Interior Panels) (USG Fiberock® Abuse-Resistant Interior Panels) (select core type), lengths as required. Identified with UL Classification label.

APPLICATION GUIDE

SPECIFICATIONS

2.2 MATERIALS CONT.

- E. Gypsum Base for Gypsum Veneer Plaster**—ASTM C1396, (1/2") (5/8") (select thickness), 4' wide, USG Imperial® Gypsum Base (Firecode® X) (Firecode® C) (select core type), lengths as required.
- F. Cement Board**—ASTM C1325, USG Durock® Brand Cement Board, 1/2" and 5/8" thickness, 48" width x 96" length.
- G. Gypsum Wallboard and Gypsum Base Joint Treatment Materials**—Select a USG Interior Finishing System
- H. Fasteners**—ASTM C1002, Screws: (3/8") (1/2") Type (S) (S-12) pan head; 5/8" Type S-12 low profile head; (1") (1-5/8") (2-1/4") Type S bugle head. USG Durock™ Brand Tile Backer Screws for steel framing: 1-5/8". Type G screws: 1-1/2".
- I. Metal Trim**—ASTM C1047, No. (200A) (200B) (401) (402) (701B) (801B).
- J.** USG Sheetrock® Brand Paper-Faced Metal Corner Bead and Trim.
- K.** Steel furring channels.
- L.** RC-1 resilient channels or equivalent.
- M.** USG steel C-H studs, (212CH-18) (212CH-34) (400CH-18) (400CH-34) (600CH-34) hot-dipped galvanized, lengths as required (select from tables).
- N.** USG steel E-studs, (400ES-34) (600ES-34) hot-dipped galvanized, lengths as required (select from tables).
- O.** USG steel J-runners, (212JR-23) (400JR-23) (600JR-23) (212JR-34) (400JR-34) (600JR-34) hot-dipped galvanized.
- P.** Steel angle clips 20 gauge, (2" x 2" x 2") (2" x 2" x 4") (horizontal shaft wall only).
- Q.** USG steel jamb struts, (212JS-34) (400JS-34) (600JS-34) hot-dipped galvanized.
- R.** Runner fasteners, power-driven type, to withstand required single shear and bearing force when driven through structural head or base and without exceeding allowable design stress in runner, fastener or structural support (obtain locally).
- S.** USG Sheetrock® Brand Acoustical Sealant.
- T.** Sound batts—(1") (1-1/2") (3").
- U.** Zinc control joint #093.

PART 3: EXECUTION

3.1 EXAMINATION

Examine substrates and abutting assemblies with installer present. Proceed with installation after conditions determined to be satisfactory.

3.2 PREPARATION

- A.** Check that system components are available to construct USG Shaft Wall System
 - USG Sheetrock® Brand Gypsum Liner Panels
 - USG Sheetrock® Brand Mold Tough® Gypsum Liner Panels
 - USG Sheetrock® Brand Glass-Mat Liner Panels
 - USG Sheetrock® Brand Firecode® X, Firecode® C, Ultracode® Core Panels
 - USG Sheetrock® Brand Mold Tough® Firecode® X, Firecode® C or Ultracode® Core Panels
 - USG Durock® Brand Cement Board
 - USG Fiberock® Abuse-Resistant Interior Panels
 - USG Fiberock® Aqua-Tough™ Interior Panels
 - USG Imperial® Gypsum Base, Firecode® X or Firecode® C
 - USG steel framing components (C-H studs, J-runner, E-studs, jamb struts)
- B.** Other fire-resistive elements/materials: Coordinate installation of USG Shaft Wall assembly with sprayed fire-resistive materials and other fire-resistive elements so both elements remain complete and undamaged.

APPLICATION GUIDE

SPECIFICATIONS

3.3 SHAFT WALL INSTALLATION

A. USG Steel Framing and USG Sheetrock® Brand Gypsum Liner Panels

1. Position steel J-runners at floor and ceiling with the short leg toward finish side of wall.
2. Securely attach runners to structural supports with powder-actuated fasteners at both ends and max. 24" o.c.
3. For attachment to steel frame construction, install floor and ceiling J-runners and J-runners or E-studs on columns and beams before steel is fireproofed.
4. For attachment to structural steel, use Z-shaped stand-off clips secured to structural steel before fireproofing application.
5. Remove spray-fireproofing from J-runners and E-studs before installing gypsum liner panels.
6. For wall heights less than maximum available panel height, cut gypsum liner panels no more than 1" less than floor-to-ceiling height and erect vertically between J-runners.
7. Where shaft wall height shaft exceeds maximum available panel length, pieces of gypsum liner panel must be butted together at factory-cut ends.
 - a. Position gypsum liner panel end joints within upper and lower third points of wall.
 - b. Stagger joints top and bottom in adjacent panels.
 - c. Screw studs to runners on walls over 16'.
8. Cut C-H studs 3/8" to not more than 1/2" less than floor-to-ceiling height.
9. Install C-H studs between gypsum liner panels with liner securely engaged.
10. Terminations: Install full-length steel E-studs or J-runners vertically at T-intersections, corners, door jambs and columns.
11. Openings: Frame with vertical E-stud or J-runner at vertical edges, horizontal J-runner at head and sill. Reinforce as shown in this brochure. Suitably frame all openings to maintain structural support for wall.
12. Elevator Door Frames: Install jamb struts each side of elevator door frames to act as strut-studs.
13. Steel Hinged Door Frames: Install floor-to-ceiling steel E-studs each side to act as strut-studs.
14. Attach strut-stud (see 3.2.A.12 or 3.2.A.13) to floor and ceiling runners with two 3/8" Type S-12 pan head screws. Attach strut-studs to jamb anchors with 1/2" Type S-12 screws. Over steel doors, install a cut-to-length section of J-Runner and attach to strut-studs with 3/8" Type S-12 screws.

B. Resilient Channels

1. Install resilient channels (RC-1 or equivalent) horizontally to face of studs, within 6" of floor and ceiling.
2. Apply resilient channels a maximum of 24" o.c. vertically (with open face up).
3. Attach resilient channels to studs with 3/8" Type S screws driven through holes in mounting flange.
4. Splice channel by nesting directly over stud; screw-attach through both flanges. Reinforce with screws at both ends of splice.
5. Install 1/2" x 3" wide continuous gypsum filler strips to top and bottom runner.
6. Gypsum panel application with resilient channel: Apply base layer horizontally to resilient channels with end joints staggered. Fasten with 1" Type S screws 12" o.c. Apply face layer vertically with joints staggered; attach to channels with 1-5/8" Type S screws 12" o.c.

C. USG Sheetrock® Brand Gypsum Panels

Gypsum panels and fastening must be per the corresponding fire-resistance design number that is the basis of design. See the Performance Selector in this brochure for specific fire-resistance design numbers. The system references below correspond to the Performance Selector found on pages 14-15.

APPLICATION GUIDE SPECIFICATIONS

3.3 SHAFT WALL INSTALLATION CONT.

Per UL Design U415, USG Sheetrock® Brand Gypsum Panels may be applied vertically or horizontally in all of the systems below, except System F. Please note appropriate fastener spacing.

System A—U415 or U469, one-hour fire-resistance rating. Apply one layer 5/8" USG Sheetrock® Brand Firecode® X Panels to studs and runners with 1" Type S or S-12 (typical) screws. Fastener spacing – Space screws 12" o.c. for vertical panel application, 8" o.c. for horizontal panel application.

System B—U415 or U438, two-hour fire-resistance rating. Apply two layers of 1/2" USG Sheetrock® Brand Firecode® C Panels. Apply base layer to studs with 1" Type S or S-12 (typical) screws. Space screws 24" o.c. along edges and in the field of the panels for vertical application, 16" o.c. for horizontal application. Apply face layer to studs and J-runners with 1-5/8" Type S or S-12 (typical) screws. Space screws 12" along the edges and in the field when applied vertically, 8" o.c. when applied horizontally. Stagger all joints between base and face layers.

System D—U415 or U459, two-hour fire-resistance rating. Install 1-1/2" Thermafiber® SAFB mineral wool batts in stud cavity. Apply base layer of 5/8" USG Sheetrock® Brand Firecode® C Panels using 1" Type S or S-12 (typical) screws spaced 24" o.c. when board is applied vertically. Space screws 16" o.c. when board is applied horizontally. Apply face layer of 1/2" USG Durock® Brand Cement Board to C-H studs with 1-5/8" USG Durock™ Tile Backer Screws spaced 8" o.c.

System E—U415 or U467, two-hour fire-resistance rating. Apply one layer 1/2" USG Sheetrock® Brand Firecode® C Panels to both sides of C-H studs. Fasten with 1" Type S or S-12 (typical) screws. Space screws 12" o.c. along the edges and in the field for vertical panel application, 8" o.c. for horizontal.

System F—U415, two-hour fire-resistance rating. Apply base layer 1/2" USG Sheetrock® Brand Firecode® C Panels to resilient channels with 1" Type S or S-12 (typical) screws spaced 24" o.c. Stagger end joints. Apply face layer 1/2" USG Sheetrock® Brand Firecode® C Panels with 1-5/8" Type S or S-12 (typical) screws spaced 12" o.c.

System G—U415, three-hour fire-resistance rating. Apply two layers of 5/8" USG Sheetrock® Brand Firecode® C Panels using Type S or S-12 (typical) screws spaced 12" o.c. Apply first and second (inner) layers vertically or horizontally over room side of steel C-H studs. When applied vertically, center joints between panels over studs. Stagger all joints a minimum 24". When panels are applied horizontally, stagger joints a minimum 12". Apply third layer of 5/8" USG Sheetrock® Brand Firecode® C Panels vertically or horizontally over room side of steel C-H studs using 2-1/4" Type S or S-12 (typical) screws. Space screws 16" o.c. when board is applied vertically, 12" o.c. when board is applied horizontally.

System H—U415, three-hour fire-resistance rating. Alternate to System G above. Apply third layer of 5/8" USG Sheetrock® Brand Firecode® C Panels to other side of steel C-H studs.

Horizontal Assemblies—Two-hour fire-resistance rating. Install three layers of 1/2" USG Sheetrock® Brand Firecode® C Panels to horizontally installed C-H and/or E-studs. Apply the base layer with 1" Type S or S-12 (typical) screws spaced 24" o.c. Apply the mid-layer in the same manner with joints offset 2' and attached with 1-5/8" Type S or S-12 (typical) screws spaced 12" o.c. Apply the face layer attached with 2-1/4" Type S or S-12 (typical) screws spaced 12" o.c. Place face layer end joints between studs and secure with 1-1/2" Type G screws 8" o.c.

Horizontal Stud Shaft Wall

1. Attach horizontal J-runners at the floor and top of wall and vertical J-runners to structural supporting elements with powder-actuated fasteners located not greater than 2" from ends and spaced no more than 24" on center with short leg of J-runner toward the finish side of the wall.
2. Install gypsum liner panels horizontally without butt joints, which limits the width of the wall to the available length of the liner panels.
3. Cut gypsum liner panels 1" less than the width of the wall, and center the panels between the vertical J-runners. The top edge of the uppermost liner panel to be cut 1" less than the wall height to clear the 1" leg of the top J-runner.

APPLICATION GUIDE

SPECIFICATIONS

3.3 SHAFT WALL INSTALLATION CONT.

4. Free edge of the uppermost and lower liner panels attached to the long leg of the top and bottom J-runners with 1-5/8" long Type S or S-12 steel screws spaced no greater than 12" on centers.
 5. Cut C-H studs to maintain a 1/4" gap at each end of the wall.
 6. Install C-H studs horizontally with the open "C" section of the studs facing down and spaced 24" o.c.
 7. Steel angles should be minimum 20 gauge, 2" x 2" x 2" for 4 C-H studs, and 2" x 2" x 4" for 6 C-H studs. Clips are centered under and tight to the web of the C-H studs, but not attached to the studs. Clips are attached through the web of the vertical J-runners to the underlying structural supporting element with a minimum of two 1/2" Type S-12 pan head screws.
 8. As an alternative to the preceding angle clip, fasten each end of the horizontal C-H stud to the vertical J-runner legs with 1/2" Type S-12 pan-head steel screws on both sides of the wall.
 9. End reactions of the horizontal C-H studs must be accommodated by the structural element required at the ends of the wall, and must be determined by a licensed professional engineer.
 10. The allowable height of the wall is predicated on the structural adequacy of the vertical structural elements.
- D. USG Sheetrock® Brand Gypsum Panels (for vertical and horizontal shaft walls) Vent Shaft Enclosure**—U529, two-hour fire-resistance rating. Install 1" x 2" x 25" ga. galvanized steel angles as runners on floor, ceilings and partition ends. Fasten runners or angles securely to structure with suitable fasteners spaced 24" o.c. max. Install 1/2" USG Sheetrock® Brand Firecode® C Panels vertically. Fasten to angles with 1" Type S or S-12 (typical) screws spaced 12" o.c. Apply USG Sheetrock® Brand Durabond® Setting-Type Joint Compound or USG Sheetrock® Brand Easy Sand™ Lightweight Setting-Type Joint Compound on back side of liner panel and sheet-laminate to shaft-side board with vertical joints offset 12" from inner board joints. Also screw to shaft-side board with 1-1/2" long Type G screws spaced 24" o.c. in both directions. Laminate face board to liner panels in similar manner. Install face boards vertically with joints offset 12" from liner panel joints. Apply pressure when placing boards to ensure good adhesive bond and fasten to liner panel with 1-1/2" Type G screws, spaced 24" o.c.
-

3.4 ACCESSORY APPLICATION

- A. Gypsum Panel Joints**—Finish all face layer joints and internal angles with a USG Sheetrock® Brand interior finishing system installed according to manufacturer's directions.
- B. Corner Bead**—Reinforce all vertical and horizontal exterior corners with USG Sheetrock® Brand Paper-Faced Metal Corner Bead.
- C. Metal Trim**—Where shaft wall terminates against masonry or other dissimilar material, apply USG Sheetrock® Brand Paper-Faced Metal Corner Bead and Trim over face layer edge.

PRODUCT INFORMATION

See usg.com for the most up-to-date product information.

NOTE

Products described here may not be available in all geographic markets. Consult your USG Company sales office or representative for information.

NOTICE

We shall not be liable for incidental or consequential damages, directly or indirectly sustained, nor for any loss caused by application of these goods not in accordance with current printed instruction or for other than the intended use. Our liability is expressly limited to replacement of defective goods. Any claim shall be deemed waived unless made in writing to us within thirty (30) days from date it was or reasonably should have been discovered.

SAFETY FIRST!

Follow good safety/industrial hygiene practices during installation. Wear appropriate personal protective equipment. Read Safety Data Sheets and literature before specification and installation.



CONTACT INFORMATION

Manufactured by
United States Gypsum Company
550 West Adams Street
Chicago, IL 60661

CUSTOMER SERVICE

800 950-3839

TECHNICAL SERVICE

800 USG.4YOU (874-4968)

WEBSITES

usg.com
usgdesignstudio.com

SA926/rev. 3-16

© 2016 USG Corporation and/or its affiliates. All rights reserved.

The trademarks USG, AQUA-TOUGH, DURABOND, DUROCK, EASY SAND, FIBEROCK, FIRECODE, FIRST COAT, IMPERIAL, MOLD TOUGH, PLUS 3, SHEETROCK, TUFF-HIDE, ULTRACODE, IT'S YOUR WORLD. BUILD IT., the USG logo, the design elements and colors, and related marks are trademarks of USG Corporation or its affiliates.

The trademarks TYPE S, S-12, and related marks are trademarks of ITW Buildex or its affiliates.

The trademarks THERMAFIBER, and related marks are trademarks of Thermafiber LLC, or its affiliates.

USG 
IT'S YOUR WORLD. BUILD IT.®